



Castle Pocket Cutter Model TSM-21



Diagnostic Manual

Castle, Inc. 1364 N. McDowell Blvd. PO Box 750236. Petaluma CA 94975
(800) 282-8338 Fax (707)765-0953 www.castleusa.com



Table of contents

<u>Section</u>	<u>Page</u>
I. Introduction, How to use this Manual	3
II. Dry Cycle Testing	4
III. Definitions	5
IV. Troubleshooting Descriptions	
1. Clamp Operation	6
2. Router Operation	7
3. Drill Operation	8
4. Overall Machine operation & Pocket Adjustment	9
V. Procedures	10-49
VI. Appendices	
A. Machine Safety	47
B. Wiring Diagram	48
C. & E. Control Box works	49 & 51
D. & F. Solenoid Pneumatic Diagram	50 & 52
G. Index	53



I. Introduction

Thank you for making the Castle TSM-21 Screw Pocket Machine a vital part of your shop. The TSM-21 is designed for use on a wide variety of materials including hardwoods, softwoods, melamine, particleboard and MDF.

This manual is intended for anyone working with, or performing maintenance or service on the TSM-21.

If trouble occurs, in most cases one of the major components is either not starting its function or not completing its function. This may lead to a skip or stall in the operational sequence.

Troubleshooting the TSM-21 is greatly aided by understanding the machine's operational sequence which occurs in this order:

1. The **Clamp** extends to secure the work piece
2. The **Router** creates the pocket then retracts
3. The **Drill** creates the Pilot screw Hole then retracts
4. The **Clamp** releases the work piece

How to use this manual:

1. Closely observe the behavior of the machine noting **which component** is involved **and when** in the operational sequence the problem is occurring.
2. Go to Section IV-Diagnostic Descriptions, which is organized by the operational sequence of the machine.
3. Find the description which most closely matches the problem and systematically perform the Diagnostic Procedures listed, checking them off as you go.

Example:

	Page	Procedure
Clamp comes down as soon as air is attached...with Machine power OFF:		
<input type="checkbox"/> Check clamp Solenoid for function or blockage	12-13	21.11

Note: If you are unsure of your observations or if the fault behavior seems irregular you should "Dry Cycle" test the machine. See Procedure 21.95, page 4.



II. Dry Cycle testing

21.95

Dry Cycle testing allows observation of the TSM-21's mechanical, electrical, and pneumatic functions without routing pockets or drilling holes.

Careful observation is essential when troubleshooting or seeking Technical Support.

TO DRY CYCLE TEST THE TSM-21:

1. Locate the ON/OFF switches on the Router and Drill and turn them **both off**, or **unplug both** motors at the Control Box outlet.
2. Connect air and power to the machine. Turn the machine's MAIN Power Switch ON.
3. Depress one of the Safety Buttons with a piece of scrap wood positioned out of the path of both the router and drill bits. Position yourself to see both the Router and Drill bits when they extend.
4. Press the Foot Pedal and observe the following actions in this order.
 1. The **Clamp** extends to secure the scrap wood
 2. The **Router** extends then retracts
 3. The **Drill** extends then retracts
 4. The **Clamp** releases the scrap wood

Total elapsed time should be approximately two seconds.

- If the cycle does not begin, check the Air Supply, the Foot Switch, and the Safety Switch: Procedures 21.92, 21.80 and 21.82
- If the cycle stalls with the router extended or if the cycle skips over the router stroke entirely, check the Router Stop Switch: Procedure 21.22
- If the cycle stalls with the drill extended or if the cycle skips over the drill stroke entirely, check the Drill Stop Switch: Procedure 21.43
- If the complete cycle takes significantly longer than two seconds, check the Air Supply, the Pressure Regulator, and the Router Feed Rate: Procedures 21.92, 21.90 and 21.32
- If the Dry Cycle is successful, but a regular cycle fails when routing actual pockets and drilling holes, check the Tooling, the Motor Operation, and the Drive Cylinder: Procedures 21.83, 21.20 and 21.60

For comprehensive diagnostic descriptions and procedures refer to Section IV.

After testing is complete, turn the MAIN Power Switch OFF and switch both motors back ON or plug them both back into the Control Box outlet.



III. Definitions

Air pressure regulator: Used to set the main operational speed of the machine. Factory set at approximately 85 PSI. / approximately 6 full clockwise turns from stop.

Bar Spring: Provides pressure to return the Motor Carriage to neutral after the Pilot Drill stroke.

Continuity testing: “Visual Indicator” type testers use batteries and a light bulb.
“Audible Indicator” type testers use batteries and a beeper or buzzer.

Normally **OPEN** (NO) switches read no continuity at rest, IE; **NO** light or sound from tester.
Normally **CLOSED** (NC) switches read continuity at rest, IE: light or sound from tester.

Drill motor: Porter Cable 7301 trimmer motor used to drill the Pilot Hole.

Drive Cylinder: A double acting air cylinder which moves the Motor Carriage backwards for the Pocket Router stroke and forwards for the Pilot Drill stroke.

Pilot hole: The Screw hole drilled by the Drill motor.

Pilot Valve: Provides full pressure to the Clamp cylinder. It is controlled by the Clamp Solenoid.
NOTE: Used up to machine SN: 61076 only.

Pocket: The pocket cut in the material by the Pocket Router motor.

Router motor: Porter Cable 6902 used to cut the Pocket.

Router Feed Rate Valve: Controls the speed at which the Pocket Router moves through the material when cutting the Pocket. **NOTE: Should be adjusted AFTER the main operational speed of the machine has been set with the Air Pressure Regulator.**

Solenoids: Electrically controlled air valves which send pressurized air to the Clamp Cylinder and Drive Cylinder. **See Appendix C & E for illustrations.**

SQE valves: Super Quick Exhaust valves which release air pressure from the drive cylinder after the Router and Drill strokes. **NOTE: Used up to machine SN: 62481 only.**

Switches: Normally **OPEN** (NO) switches
Foot Switch
Safety Switch

Normally **CLOSED** (NC) switches
Router Stop Switch
Drill Stop switch

Web: The distance between the deepest part of the pocket and the edge of the material.



IV. Diagnostic Descriptions

1. Clamp Operation

	Page	Procedure
Clamp <u>doesn't come down, but Machine Routs and Drills:</u>		
<input type="checkbox"/> Check Clamp cylinder air line for leakage.....	14-15	21.12
<input type="checkbox"/> Check Clamp Solenoid for blockage.....	11	21.10
<input type="checkbox"/> Check Pilot Valve for function or blockage (up to machine sn: 61076 Only)... 17		21.14
Clamp <u>comes down and STAYS DOWN as soon as air is attached...with Machine power OFF:</u>		
<input type="checkbox"/> Check Clamp Solenoid for function	12-13	21.11
Clamp <u>comes down, but immediately retracts...Machine does not Rout or Drill:</u>		
<input type="checkbox"/> Check Drill Stop Switch.....	31-32	21.43
Clamp <u>doesn't hold stock securely:</u>		
<input type="checkbox"/> Clamp footpad replacement	10	21.01
<input type="checkbox"/> Internal Air Pressure too low, adjust Pressure regulator.....	46	21.90
<input type="checkbox"/> Router Feed Speed too fast, adjust Router Feed Rate	26	21.32
<input type="checkbox"/> Check Tooling, may be dull	44-45	21.83
<input type="checkbox"/> Check Pilot Valve for function or blockage (up to machine sn: 61076 Only)... 17		21.14
Clamp <u>releases slowly, Machine Routs and Drills:</u>		
<input type="checkbox"/> Check Clamp cylinder and air line	14-15	21.12
<input type="checkbox"/> Check Pilot Valve exhaust port (up to machine sn: 61076 Only)..... 16		21.13
<input type="checkbox"/> Check Pilot Valve for function or blockage (up to machine sn: 61076 Only)... 17		21.14
<input type="checkbox"/> Check Clamp Solenoid for blockage	11	21.10
Clamp <u>doesn't release...Machine Routs, and Drills:</u>		
<input type="checkbox"/> Adjust internal Air Pressure.....	46	21.90
<input type="checkbox"/> Check Pilot Valve for function or blockage (up to machine sn: 61076 Only) ... 17		21.14
<input type="checkbox"/> Check Drill Stop Switch	31-32	21.43
<input type="checkbox"/> Check Foot Switch	41	21.80
Clamp <u>doesn't release...Machine Routs, DOES NOT Drill:</u>		
<input type="checkbox"/> Check Pilot Valve for function or blockage (up to machine sn: 61076 Only)... 17		21.14
<input type="checkbox"/> Check Drill Solenoid for function or blockage.....	34-35	21.51
Clamp <u>doesn't release...Machine Routs but Router DOES NOT retract, DOES NOT Drill:</u>		
<input type="checkbox"/> Router Stop switch.....	21-22	21.22



2. Router Operation

	Page	Procedure
Router <u>doesn't cut pocket...Machine Clamps and Drills, but Clamp DOES NOT release:</u>		
<input type="checkbox"/> Check Router Feed Rate, may be turned all the way down	26	21.32
<input type="checkbox"/> Check Router Solenoid for function or blockage	24-25	21.31
<input type="checkbox"/> Unclog Router Solenoid	23	21.30
<input type="checkbox"/> Router Motor Operation	18-19	21.20
<input type="checkbox"/> Check Router SQE Valve (or Solenoid exhaust port) for leakage.....	38-39	21.61
<input type="checkbox"/> Check Drill SQE Valve (or Solenoid exhaust port) for leakage.....	38-39	21.61
 Router <u>doesn't cut pocket... Machine Clamps, Drills and releases:</u>		
<input type="checkbox"/> Check Router Stop Switch for function or adjustment	21-22	21.22
 Router <u>comes up and STAYS UP as soon as air is attached.....with Machine power OFF:</u>		
<input type="checkbox"/> Check Router Solenoid for function or blockage	24-25	21.31
<input type="checkbox"/> Unclog Router Solenoid	23	21.30
 Router <u>cuts pocket and STAYS UP, Drill doesn't come out and Clamp doesn't release:</u>		
<input type="checkbox"/> Check Router Stop Switch for function or adjustment	21-22	21.22
 Router <u>cuts pocket, Drill doesn't come out and Clamp doesn't release:</u>		
<input type="checkbox"/> Check Drill Solenoid for function or blockage	33	21.50
 Router <u>advances too aggressively:</u>		
<input type="checkbox"/> Adjust internal Air Pressure.....	46	21.90
<input type="checkbox"/> Adjust the Router Feed Rate.....	26	21.32



3. Drill Operation

	Page	Procedure
<u>Drill DOES NOT come out, Machine Routs, Clamp DOES NOT release, :</u>		
<input type="checkbox"/> Check Drill Solenoid for function or blockage	34-35	21.51
<input type="checkbox"/> Unclog Drill Solenoid	33	21.50
<u>Drill comes out and stays out as soon as air is attached...with Machine power OFF:</u>		
<input type="checkbox"/> Check Drill Solenoid for function or blockage	34-35	21.51
<input type="checkbox"/> Unclog Drill Solenoid	33	21.50
<u>Drill comes out and stops, Router cuts pocket and Clamp DOES NOT release:</u>		
Machine DOES NOT finish cycle when carriage is pushed forward by hand:		
<input type="checkbox"/> Check Drill Motor is On	27-28	21.40
<input type="checkbox"/> Check Drill Stop Switch for function or adjustment	31-32	21.43
<u>Drill comes out and stops, Router cuts pocket and Clamp DOES NOT release:</u>		
Machine DOES finish cycle when carriage is pushed forward by hand:		
<input type="checkbox"/> Adjust Air pressure, may be too low.....	46	21.90
<input type="checkbox"/> Check Drill Solenoid for function or blockage.....	34-35	21.51
<input type="checkbox"/> Unclog Drill Solenoid	33	21.50
<input type="checkbox"/> Check Router SQE Valve (or Solenoid exhaust port) for leakage.....	38-39	21.61
<input type="checkbox"/> Check Drill SQE Valve (or Solenoid exhaust port) for leakage.....	38-39	21.61
<u>Drill bit not completing pilot hole into Pocket:</u>		
<input type="checkbox"/> Adjust air pressure, Machine cycling too slowly.....	46	21.90
<input type="checkbox"/> Bit mounted too deep into collet.....	29	21.41
<u>Drill bit separating from the shank:</u>		
<input type="checkbox"/> Adjust air pressure, Machine cycling too slowly.....	46	21.90
<input type="checkbox"/> Bit extended too far out of collet.....	29	21.41
<u>Drill bit breaking:</u>		
<input type="checkbox"/> Adjust air pressure, Machine cycling too fast.....	46	21.90
<input type="checkbox"/> Bit extended too far out of collet.....	29	21.41
<input type="checkbox"/> Check Drill T-Handle bolt	27-28	21.40



4. Overall Machine operation and Pocket Adjustment

	Page	Procedure
Machine <u>will not start cycle...motors are running:</u>		
<input type="checkbox"/> Check Air Supply, minimum 85 PSI required.....	49	21.92
<input type="checkbox"/> Check Safety Switch	43	21.82
<input type="checkbox"/> Check Foot Switch	41	21.80
 Machine <u>can be cycled with no stock in place:</u>		
<input type="checkbox"/> Check the Safety Switch	43	21.82
 Machine <u>cycling too slowly – NOTE: A normal cycle is approximately 2 seconds:</u>		
<input type="checkbox"/> Adjust Air Pressure Regulator	46	21.90
<input type="checkbox"/> Check Drive cylinder for air leak	36-37	21.60
<input type="checkbox"/> Check for other air driven machines on the same line	46	21.90
 <div style="text-align: right;">Page Procedure</div>		
Pocket <u>ragged or crooked:</u>		
<input type="checkbox"/> Adjust Router Feed Rate, may be too fast,.....	26	21.32
<input type="checkbox"/> Check Clamp footpad, may need replacement	10	21.01
<input type="checkbox"/> Check Tooling, may be dull	44-45	21.83
 Pocket <u>burned or smoking:</u>		
<input type="checkbox"/> Adjust Router Feed Rate, may be too slow,.....	26	21.32
<input type="checkbox"/> Check Tooling, may be dull	44-45	21.83
 Pocket <u>misaligned with pilot hole:</u>		
<input type="checkbox"/> Adjust Pilot Hole alignment	40	21.72
<input type="checkbox"/> Check Drill motor mounting	28-29	21.40
 Pocket <u>too close or too far from the edge of the stock, WEB adjustment:</u>		
<input type="checkbox"/> Adjust Web with Router Stop Plate	20	21.21



Castle TSM-21

Clamp Foot Pad or Cylinder Replacement 21.01

TO REPLACE THE CLAMP FOOT PAD:

1. The Clamp Foot Pad is not attached by adhesive. While the Clamp Foot is still attached to the machine, use a flat blade screwdriver to remove the old Pad by carefully levering it out of its seat.
2. The rim of the new Pad must be bent and popped into place. Insert an edge of the new pad into the Clamp Foot and use a flat blade screwdriver to wedge the rest of the Foot Pad into the Clamp Foot.

TO REPLACE THE CLAMP FOOT OR CLAMP CYLINDER:

1. Connect 85 PSI directly to the Clamp Cylinder to manually actuate it.
2. With the shaft fully extended, hold the shaft stationary with a $\frac{1}{2}$ " wrench and loosen the jamb nut with a $\frac{3}{4}$ " wrench. Continue holding the shaft stationary with the $\frac{1}{2}$ " wrench and use large slip-joint pliers to turn the Clamp Foot and break it free of thread lock compound.
See fig. 1.
3. The Clamp foot can now be removed for replacement, or to allow for removal of the Clamp Cylinder assembly.

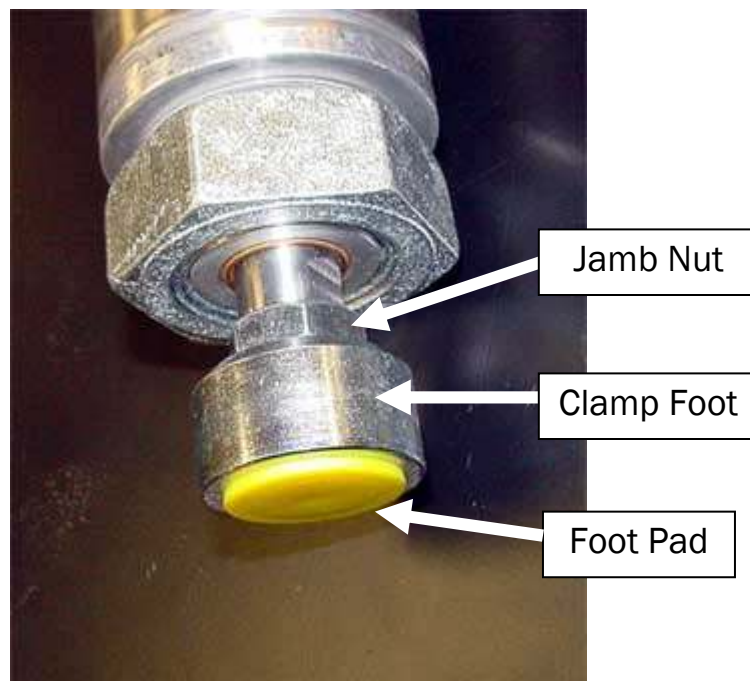

Figure 1.



Castle TSM-21

Unclogging the Clamp Solenoid

21.10

NOTE: All Solenoid Air Fittings are “Push In” connections. To remove an air line, push in the plastic or metal rim of the fitting and pull the air line out. To re-install, push the air line in until it meets resistance and then push in another 1/2”

The appearance of the solenoids may differ. See Appendix E, page 51 for equivalent illustration on machines SN: 61076 and above.

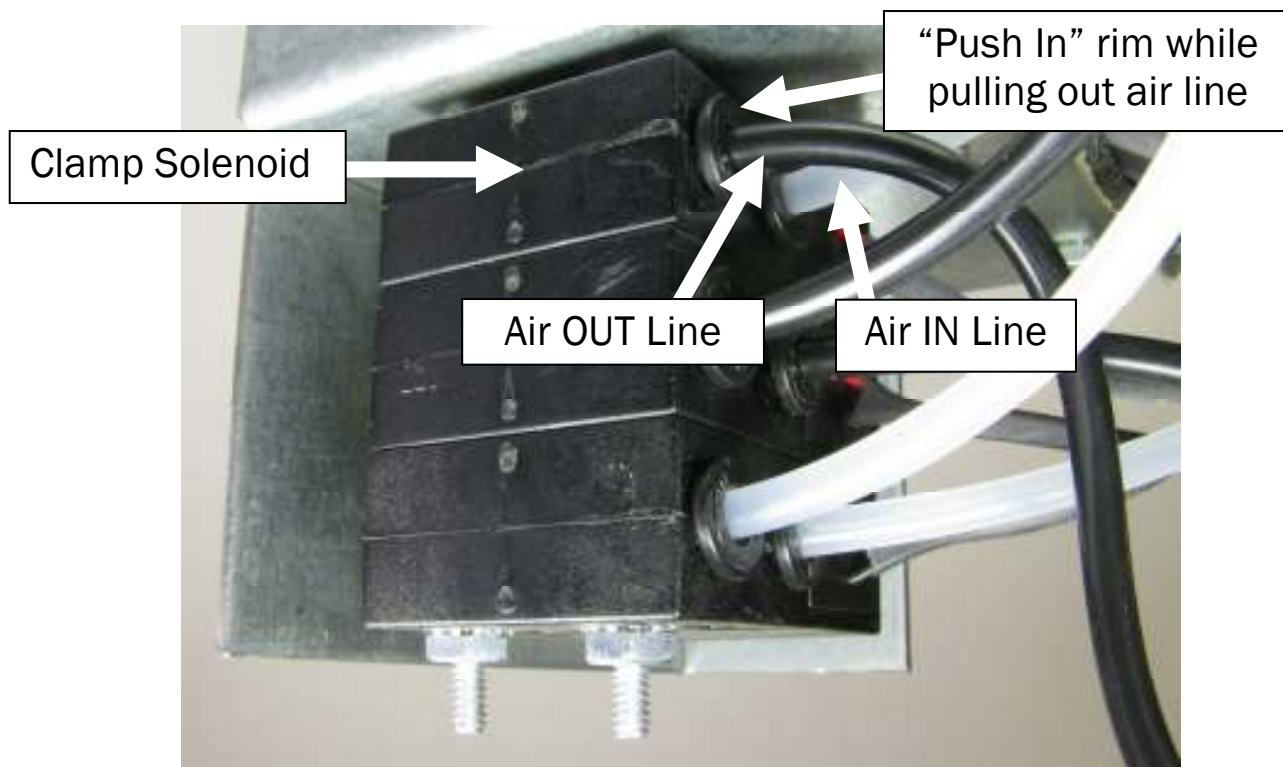

Figure 2

1. **Disconnect power and air from the machine.** Remove both air lines from the Clamp Solenoid. **See fig. 2.**
2. Reconnect air to the machine and the “Air In” line will now be flowing with about 85 PSI. Use the “Air In” line to clean out both open ports on the Clamp solenoid.
3. Disconnect the air supply and reinsert the “Air In” line back into the “Air In” port of the solenoid.
4. Un-plug or turn off both routers.
5. Reconnect power and air to the machine, and turn the Power Switch ON.
6. Place a board against the Safety Buttons and depress the Foot Pedal. Air should now be flowing from the “Air Out” port of the solenoid.
7. Turn the Power Switch OFF and repeat steps 5 and 6 several times to ensure all contaminants are expelled, then reinsert the remaining hose back into the “Air Out” port of the Clamp Solenoid.
8. Turn the routers back on and cut a test pocket.

If this procedure does not correct the problem, the Clamp Solenoid will need to be replaced.

Refer to Procedure 21.91, “Replacing Solenoids” page 47-48



Castle TSM-21

Clamp Solenoid Check

21.11

The Clamp Solenoid signals the Pilot Valve to provide full air pressure to the Clamp. If the Clamp Solenoid has failed open the clamp will come down as soon as air is attached to the machine, without the power being turned on.

The appearance of the solenoids may differ. See Appendix E, page 51 for equivalent illustration for machines SN: 61076 and above.

TROUBLESHOOTING STEPS:

1. Disconnect air supply from the machine.
2. Swap the "Air Out" lines between the Clamp Solenoid and the Router Solenoid. **See fig. 3.**
3. Reconnect the air supply to the machine and see if the router now actuates instead of the clamp. If it does the Clamp Solenoid has stuck open.
4. Swap the air lines back again.
5. **Perform procedure 21.10, "Unclogging the Clamp Solenoid".**

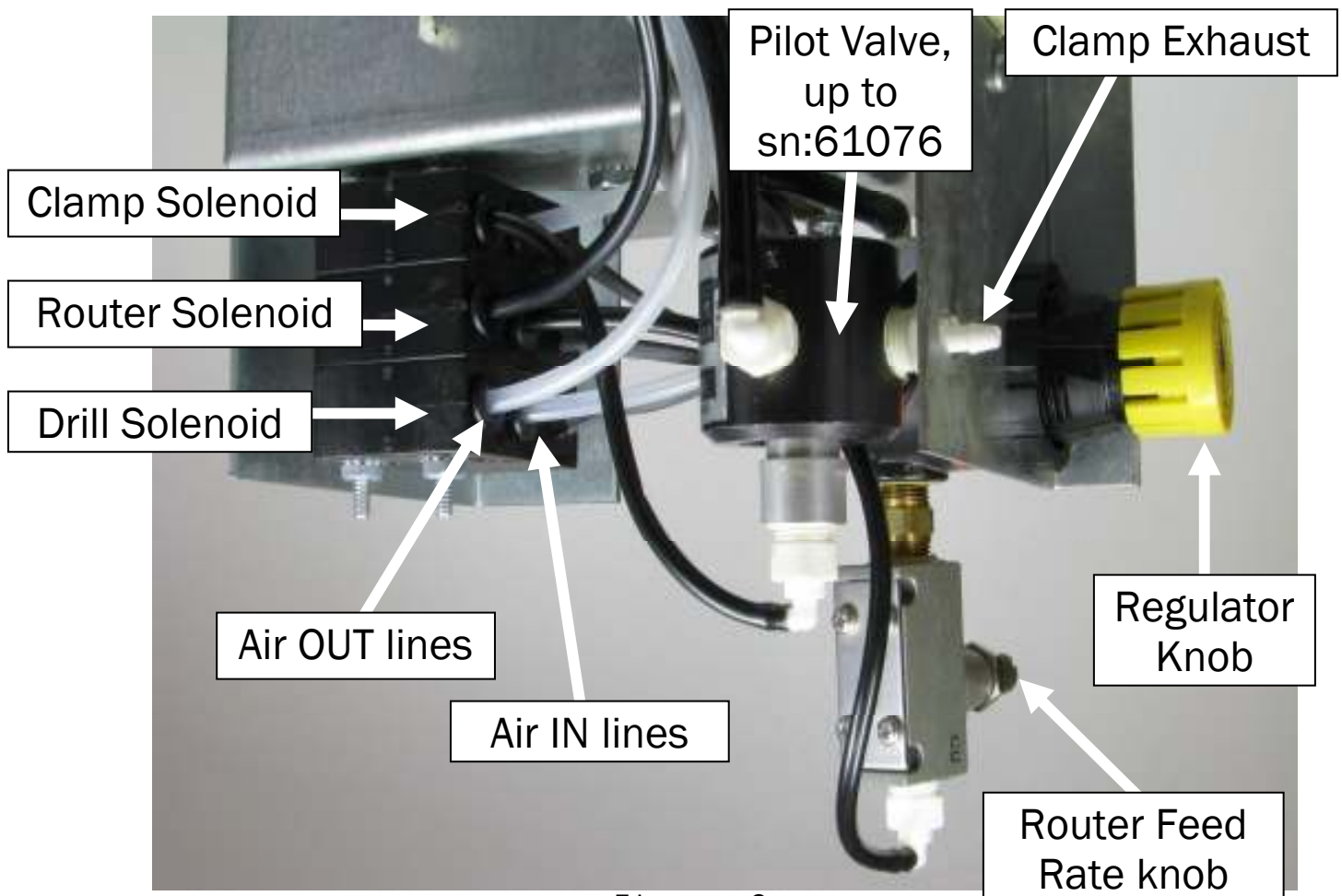

Figure 3



Castle TSM-21

Clamp Cylinder Check

21.12

If the Clamp Cylinder clamps or retracts slowly it is having trouble filling or exhausting, or it may be faulty. If the clamp operates normally with an external air supply, look for a crimp in the black ¼" air line from the Clamp Cylinder to the Pilot Valve (up to machine sn: 61076) or from the Clamp Cylinder to the Clamp Solenoid (machine sn:61076 and up).

TROUBLESHOOTING STEPS:

1. **Disconnect power and air from the machine.**
2. Disconnect the air line from the "push in" fitting of the Clamp Cylinder.
3. Connect an external air supply directly to the "push in" air fitting. **See fig.5**
The Clamp Foot should fully extend quickly. Remove the external air supply and the Clamp Foot should fully retract quickly.
4. If both clamp actions are smooth and quick the Clamp Cylinder is operating properly. Continue troubleshooting the Clamp Cylinder Air Line, the Pilot Valve (on Mead solenoid machines) and the Clamp Solenoid. **See fig. 6.**
5. If the clamping and releasing actions are not smooth and quick, the Clamp Cylinder should be replaced.

NOTE: Do not use lubricants or connect a lubricator to the machine.

(Most lubricants will damage the pneumatic seals in the air system.)

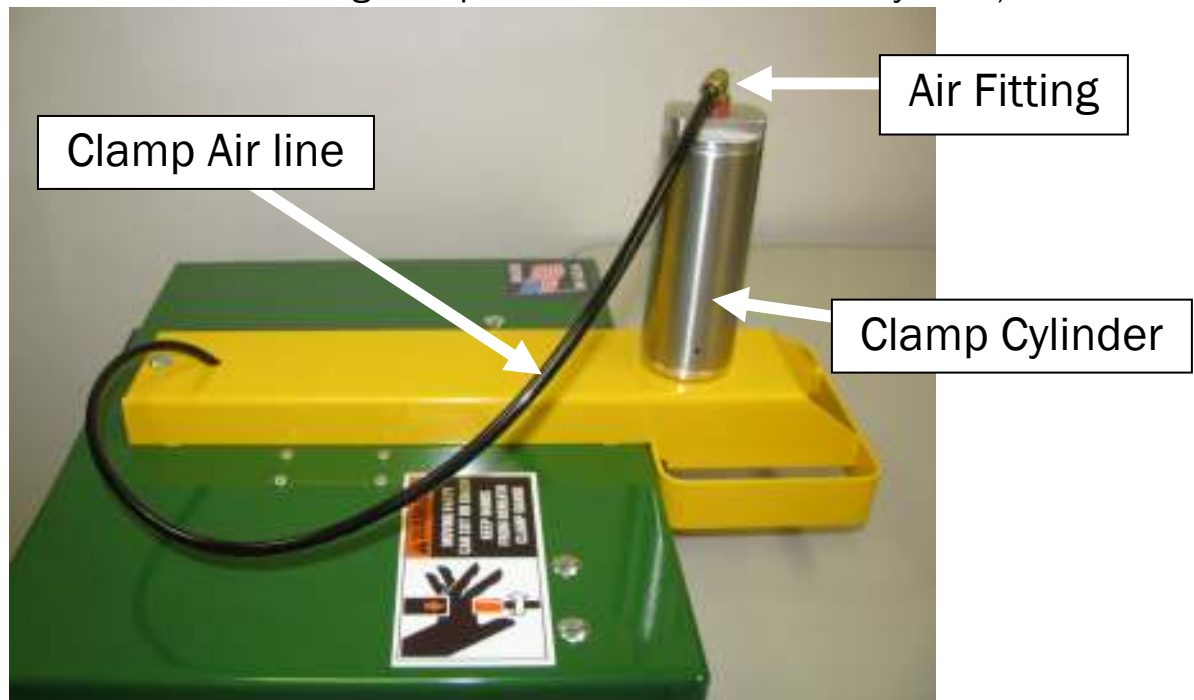

Figure 5

Continued...

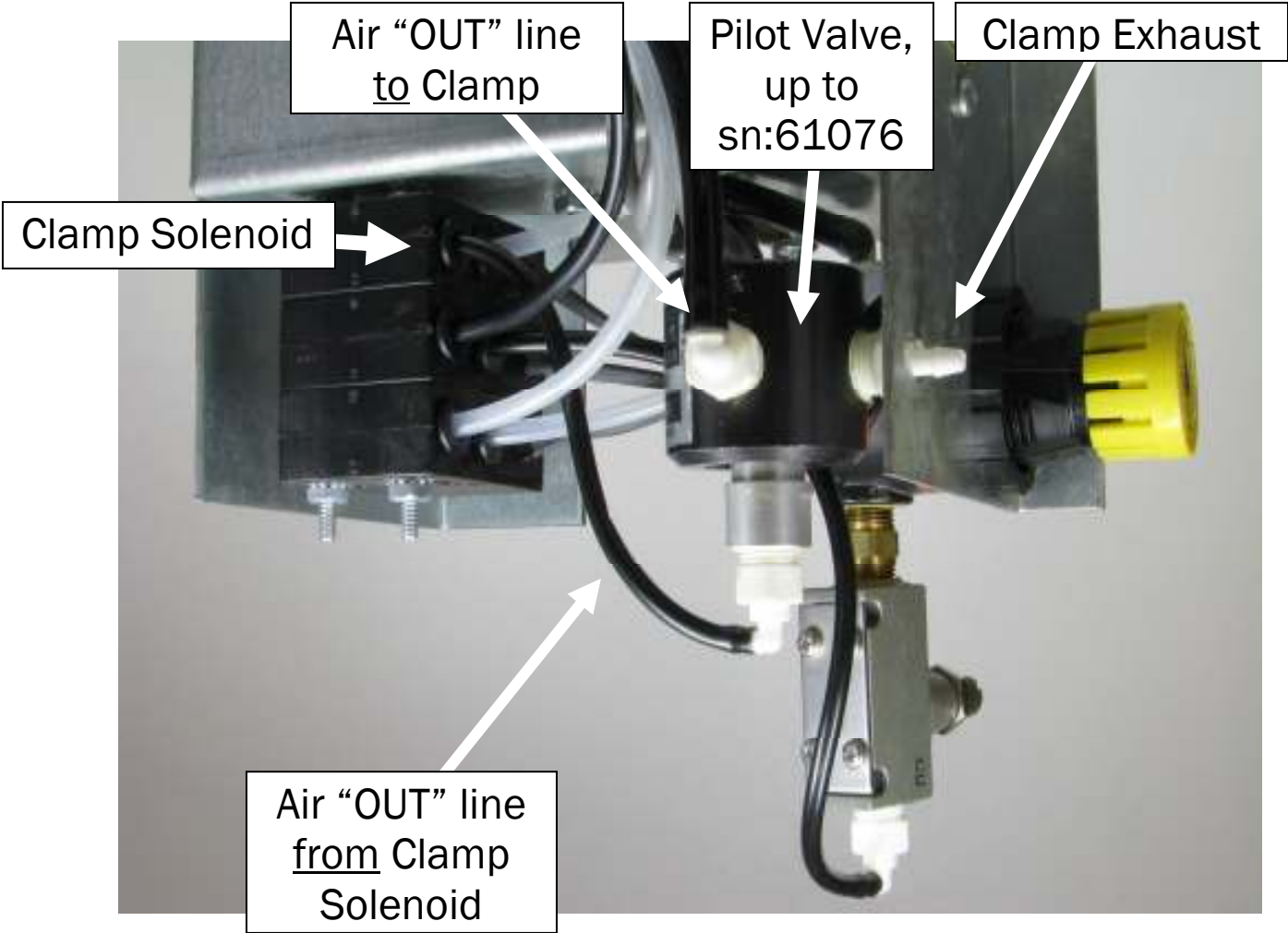

Figure 6



Castle TSM-21

Pilot Valve, Clamp Exhaust Check

21.13

(This procedure applies only to machines up to sn: 61076.)

Air from the Clamp Cylinder is exhausted out of the Pilot Valve Exhaust port. This port is located to the left of the Air Pressure Regulator knob. If the clamp fails to extend, or releases very slowly, the Pilot Valve Exhaust Port may be blocked.

TROUBLESHOOTING STEPS:

1. Open the rear door on the machine. The Exhaust port is the small, white plastic barb to the left of the regulator knob. **See fig. 7.**
2. Make sure that this port is clear of debris and unobstructed by the sheet metal case.

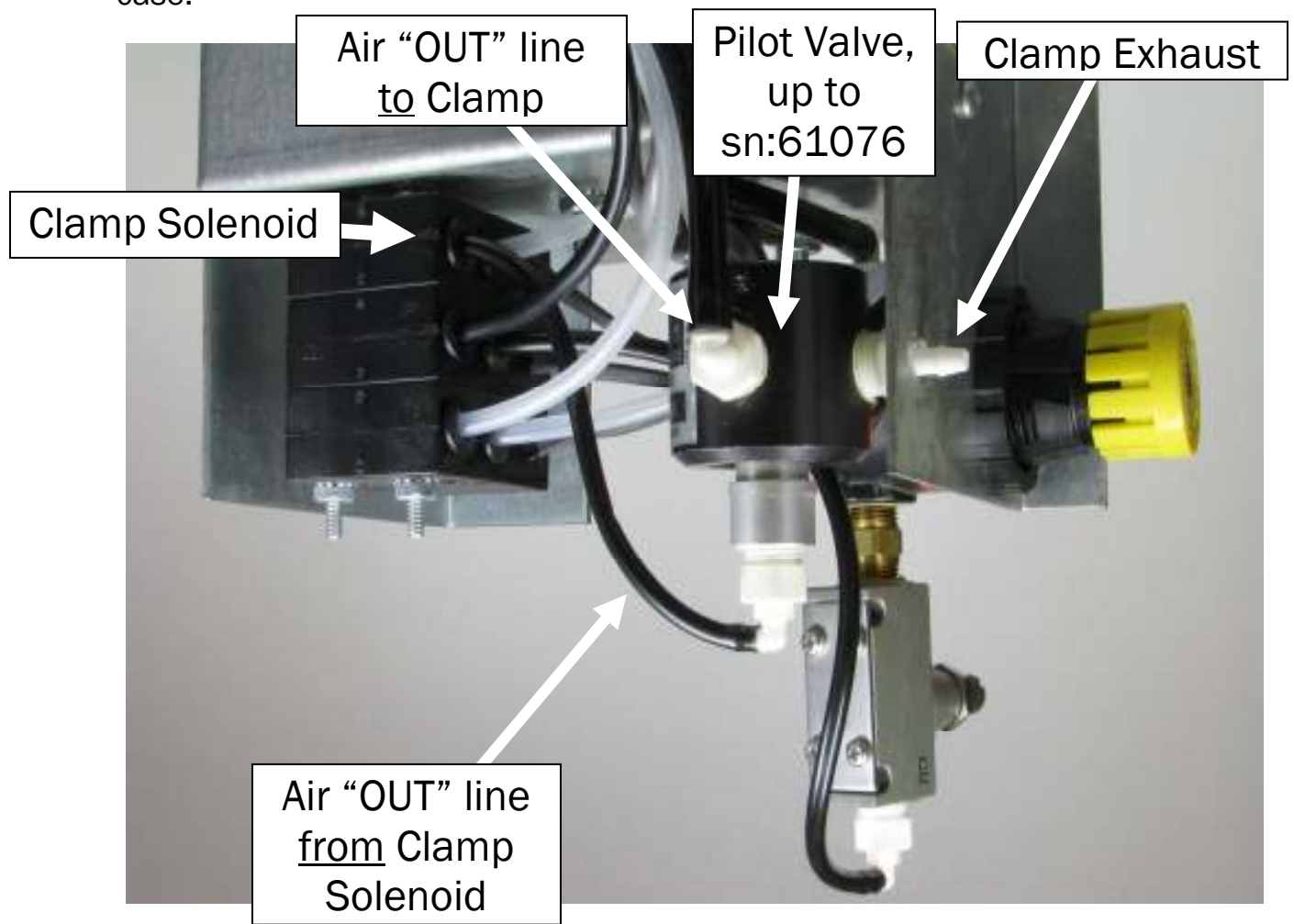

Figure 7



Castle TSM-21

Pilot Valve Check & Replacement

21.14

(This procedure applies only to machines up to sn: 61076.)

The Pilot Valve provides full air pressure to the Clamp Cylinder. A leaking Pilot Valve can result in insufficient air pressure to the Clamp regardless of the Pressure regulator setting.

TROUBLESHOOTING STEPS:

1. Disconnect the "Air Out" line from the Clamp Solenoid (this hose controls the Pilot Valve). **See fig. 8.**
2. When a cycle is started, air should now come out of the Clamp Solenoid's output port.
3. Attach an independent air supply directly to the bottom hose controlling the Pilot Valve. The clamp should extend.
4. When the independent air supply is removed from the bottom hose the clamp should release.
5. If the clamp doesn't extend, or extends but doesn't release, or constantly exhausts replace the Pilot Valve.

REPLACEMENT STEPS:

1. **Disconnect power and air from the machine.**
2. Remove the two carriage bolts securing the Control Box and pull the box partially out of the rear door.
3. Remove the plastic nut that holds the Pressure Regulator assembly to the Control Box.
4. Remove the two black hoses connected to the Pilot Valve.
5. Remove the Pilot Valve from the brass fittings.
6. Transfer the three white plastic fittings to the corresponding positions on the new Pilot valve.
7. Apply Teflon tape to the brass fitting still attached to the regulator.
8. Tighten the Pilot Valve onto the brass fitting.
9. Reattach the three plastic fittings and black hoses to the new Pilot Valve.
10. Put the plastic nut back on the regulator and tighten.
11. Re-install the Control Box using the carriage bolts.
12. Reconnect air and then power to the machine.

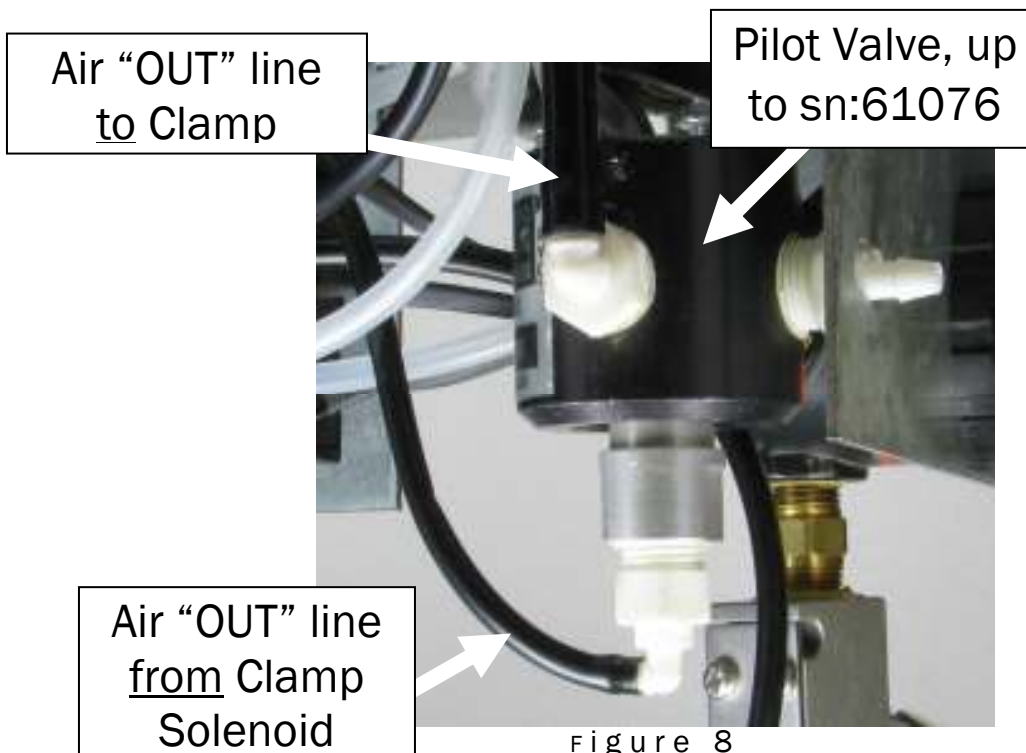

Figure 8



Castle TSM-21

Router Motor Operation

21.20

The Router Motor has its own power switch located on the motor body. This switch should be in the ON position as motor operation is controlled by the main Power Switch on the machine.

Do not run the motor for more than two hours at a time. The motor requires a ½ hour cool down period after each two hour period.

REMOVING / INSTALLING THE ROUTER MOTOR:

1. Disconnect power and air from the machine.

1. Open the rear door and locate the Drill Motor. Just to the right is a T-Knob that tightens a large U-Bolt holding the Router Motor in place. **See fig. 9.**
2. Unplug the Router motor.
3. With your right hand loosen the Router T-Knob a few turns to provide enough slack to drop the Router Motor down into your left hand and then out the rear door.

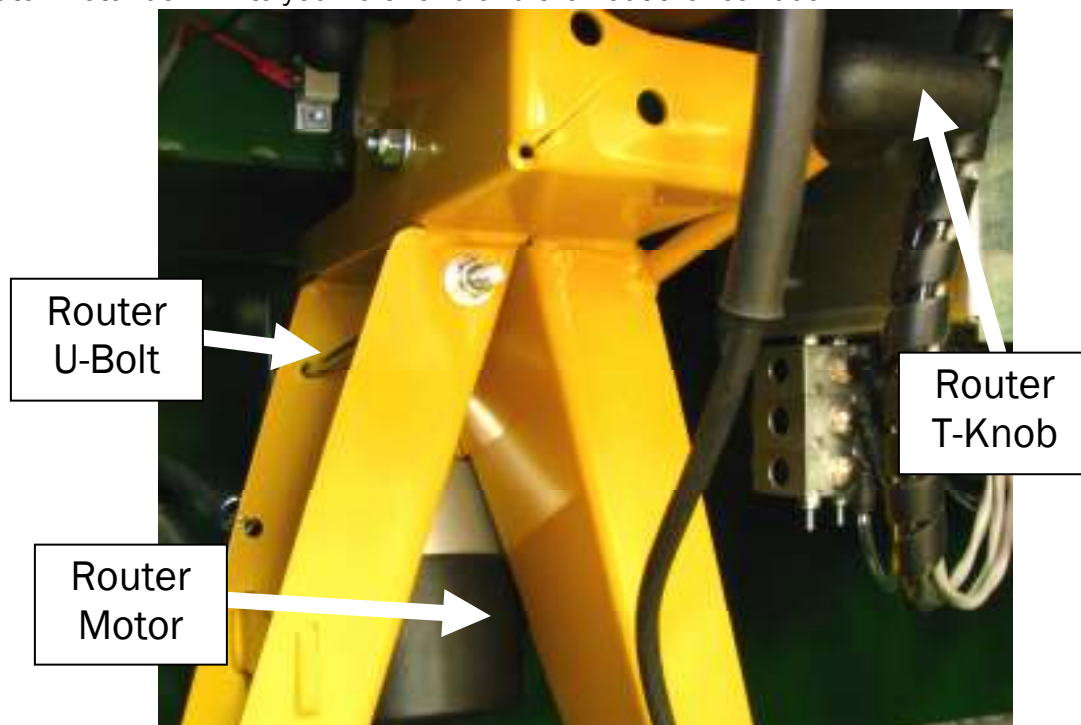

Figure 9

4. When re-installing, make sure the motor face is pushed up to seat flush with the tabs on the yellow carriage (if unsure, remove table top to confirm location).
5. Tighten the black T-Knob onto the U-Bolt. Hold the motor face flush with the yellow carriage tabs until the motor has been fully secured by the U-Bolt.
6. Manually rock the Motor Carriage toward the rear of the machine and make sure that the router bit cleanly fits in the slot on the table top.

Continued...

21.20 Continued

SERVICING THE ROUTER MOTOR:

1. Follow the instructions found in your Porter Cable manual on maintaining the motor. This includes information on keeping the motor clean and free of dust, maintaining the brushes and replacing the tooling.
2. The Router motor is warranted for one year from the purchase of the machine.
3. Warranty replacement and parts purchases can be handled by your nearest Porter Cable dealer/service center, or Castle.
4. The Router Motor has two electrical brushes that should be periodically replaced.
See fig. 10.



Figure 10



Castle TSM-21

Adjusting the Web, Router Stop Plate

21.21

The space between the edge of the stock and the deepest part of the pocket is called the “Web”. The Web may be set between $\frac{5}{8}$ ” and $\frac{13}{16}$ ” by adjusting the Router Stop Plate from the top of the machine. The factory setting is approximately $\frac{7}{8}$ ”.

If you experience inconsistent web size, make sure the lock nut on the Router Stop Plate is secure.

WEB ADJUSTMENT STEPS:

1. The Router Stop Plate is a black bracket found on the right side of the yellow Clamp Guard. It is held in place by a $\frac{1}{4}$ ” lock nut. **See fig. 11.**
2. Adjust the Web length by loosening the lock nut and moving the Router Stop Plate towards the front of the machine for a longer web and towards the back of the machine for a shorter Web.
3. Secure the lock nut after making any adjustments.

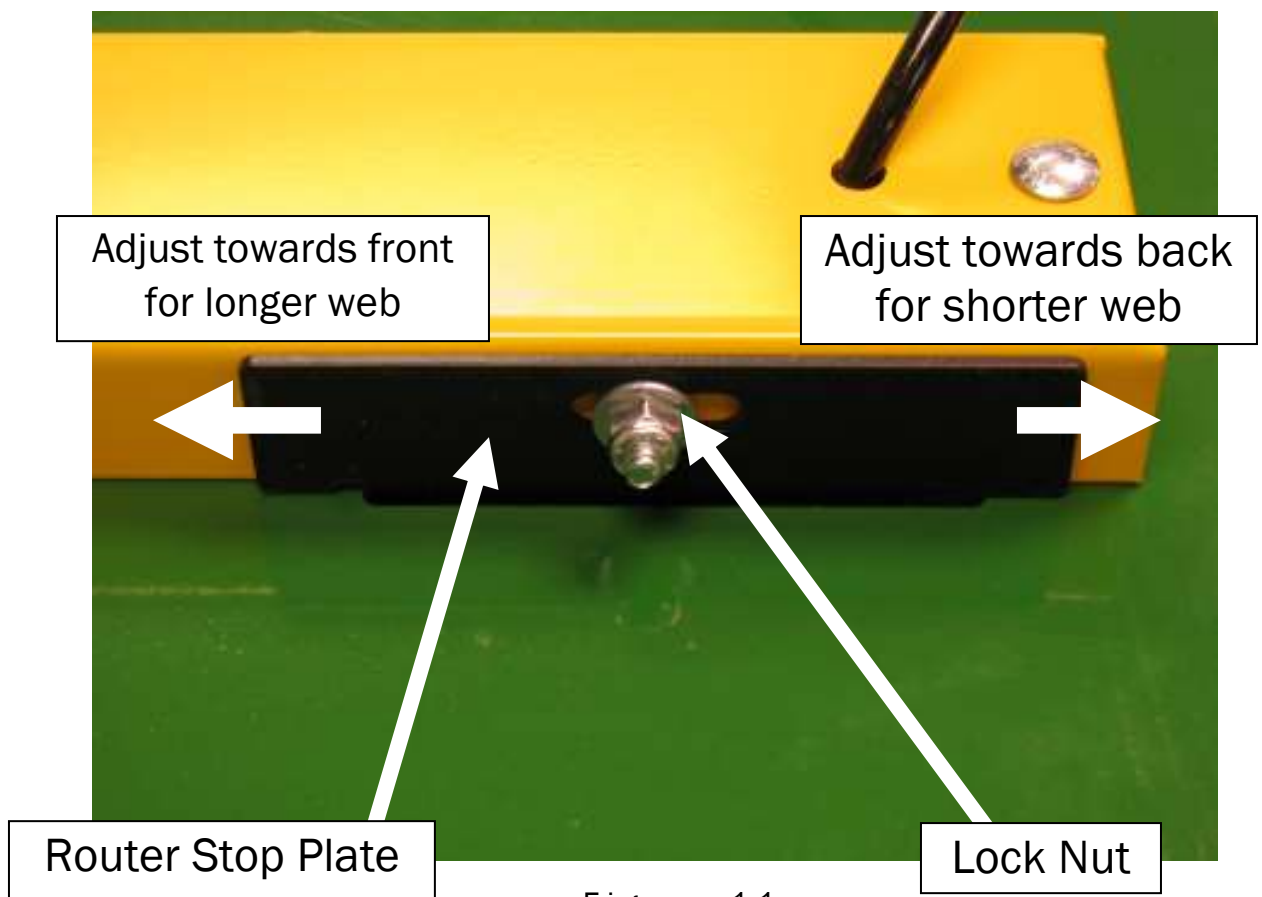

Figure 11



Castle TSM-21

Router Stop Switch (NC)

21.22

The Router Stop Switch consists of a magnetic reed switch (with wires) and a magnet (no wires). It is Normally CLOSED (NC) and OPENS at the end of the pocket routing stroke when the Motor Carriage breaks the magnetic field. The switch signals two solenoid valves that reverse the direction of airflow in the drive cylinder causing the carriage to retract the Router and extend the Pilot Hole Drill.

If the switch fails, or the magnetic field weakens or becomes misaligned, the machine will not sense the end of the rout cycle properly and the router may stay forward in the pocket causing the cycle to stall, or the router may not extend at all although the Pilot Hole Drill and Clamp finish the cycle.

TROUBLESHOOTING STEPS:

1. **Disconnect power and air from the machine.**
2. The Router Stop Switch and Magnet are attached to the back side of the Router Stop Plate, which is located just to the left of the Drill motor. **See fig. 12.**
3. Test for continuity across the terminals of the switch with the Motor Carriage in the Neutral position. The switch should measure as CLOSED.
4. Pull the carriage toward the rear of the machine until it stops against the Router Stop Plate. The switch should now measure as OPEN.
5. If the switch does not OPEN, adjust the magnet $\frac{1}{16}$ " farther away from the switch and repeat **step 4** until the switch measures OPEN with the carriage held against the Stop Plate.
6. If the switch continuously measures CLOSED regardless how far away the magnet is, replace the switch and magnet.
7. If the switch measures OPEN while the Motor Carriage is in neutral position, adjust the magnet $\frac{1}{16}$ " closer to the switch and repeat the test. Make additional adjustments closer until the switch measures CLOSED.
8. If the switch continuously measures OPEN regardless how close the magnet is, replace the switch and magnet.

Continued...

Page 20

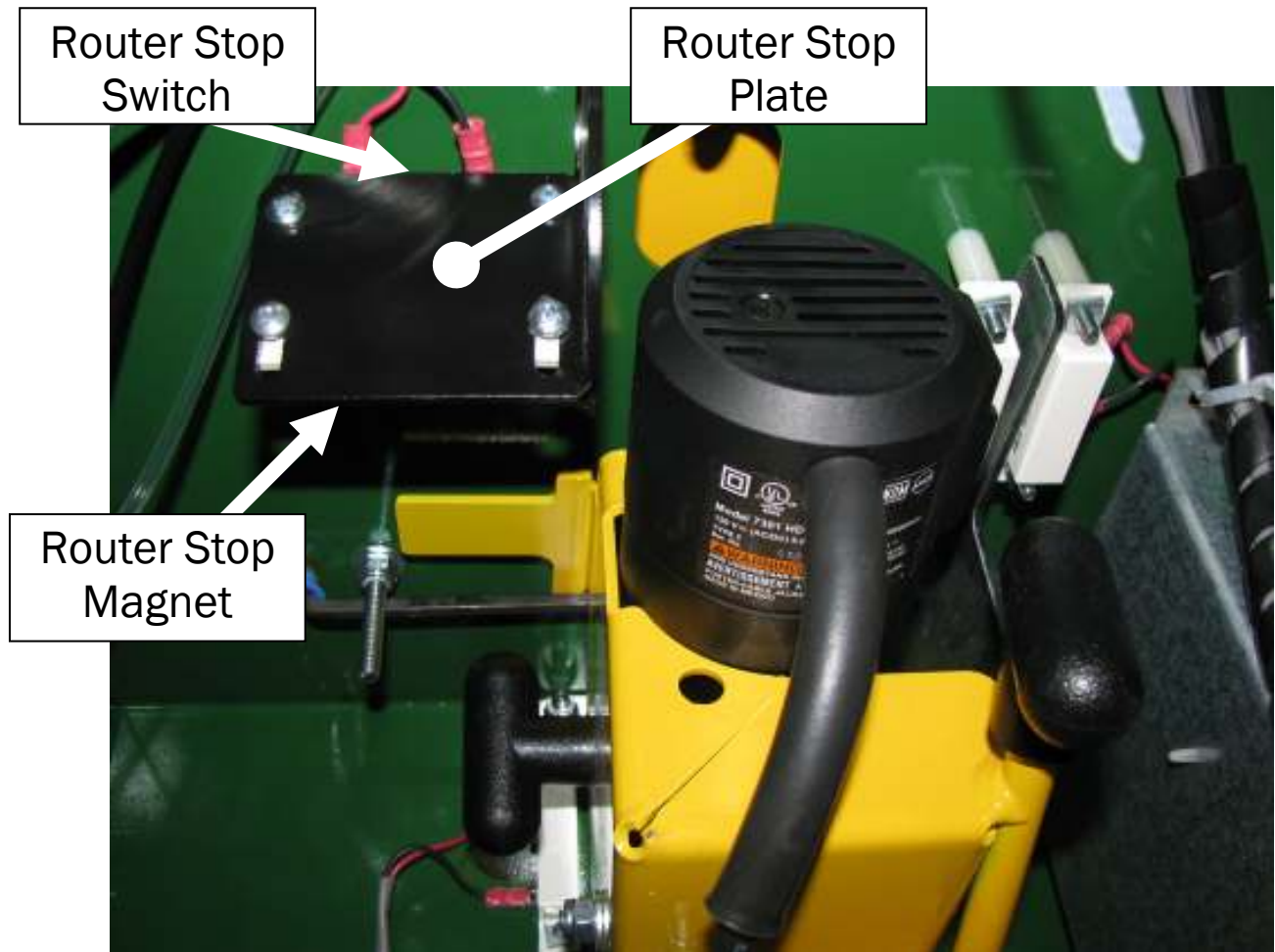

Figure 12



Castle TSM-21

Unclogging the Router Solenoid

21.30

NOTE: All Solenoid Air Fittings are “Push In” connections. To remove an air line, push in the plastic or metal rim of the fitting and pull the air line out. To re-install, push the air line in until it meets resistance and then push in another ½”

The appearance of the solenoids may differ. See Appendix E, page 51 for equivalent illustration for machines SN: 61076 and above.

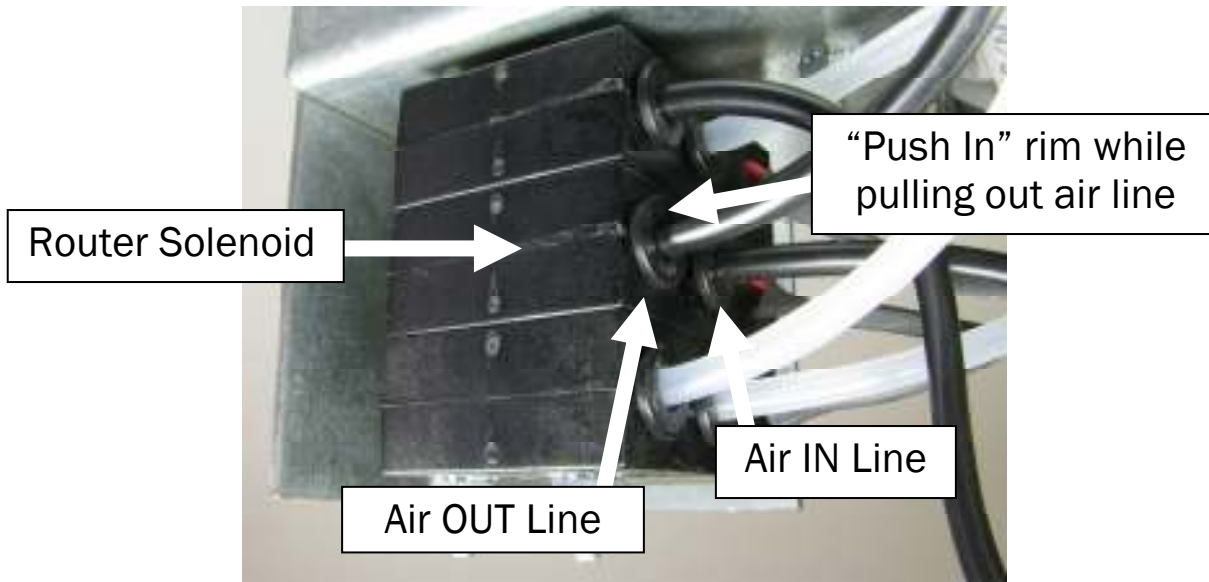

Figure 13

1. **Disconnect power and air from the machine.** Remove both air lines from the Router Solenoid. **See fig.13.**
2. Reconnect air to the machine and the “Air In” line will now be flowing with about 85 PSI. Use the “Air In” line to clean out both open ports on the Router solenoid.
3. Disconnect the air supply and reinsert the “Air In” line back into the “Air In” port of the Router solenoid.
4. Un-plug or turn off both routers.
5. Reconnect power and air to the machine, and turn the Power Switch ON.
6. Put a board against the Safety Buttons and depress the Foot Pedal. Air should now be flowing from the “Air Out” port of the valve. Gently open the Router Feed Rate valve (located on the left hand side of the machine below the air inlet) fully counter clockwise.
7. Turn the Power Switch OFF and repeat steps 5 and 6 several times to ensure all contaminants are expelled, then reinsert the remaining hose back into the “Air Out” port of the valve.
8. Turn the routers back on and cut a test pocket.
9. Turn the Router Feed Rate valve clockwise while cutting test pockets until the desired Router Feed Speed is reached.

If this procedure does not correct the problem, the Router Solenoid will need to be replaced.

Refer to Procedure 21.91, “Replacing Solenoids” page 47-48



Castle TSM-21

Router Solenoid Check

21.31

The Router Solenoid controls air pressure to the Drive Cylinder, which provides the forward motion of the router's cutting stroke. If the Router Solenoid has failed open, the Router will extend as soon as the air is attached to the machine, regardless of whether the power is turned on. If the Router Solenoid is clogged, the Router may not start or complete the pocket.

The appearance of the solenoids may differ. See Appendix E, page 51 for equivalent illustration for machines SN: 61076 and above.

TROUBLESHOOTING STEPS:

1. Detach the air supply from the machine.
2. Swap the "Air Out" lines between the Router Solenoid and the Drill Solenoid. **See fig. 14.**
3. Attach the air supply to the machine and see if the drill now extends instead of the router. If it does, the Router Solenoid has stuck open.
4. Swap the air lines back again.
5. **Perform procedure 21.30 "Unclogging the Router Solenoid".**

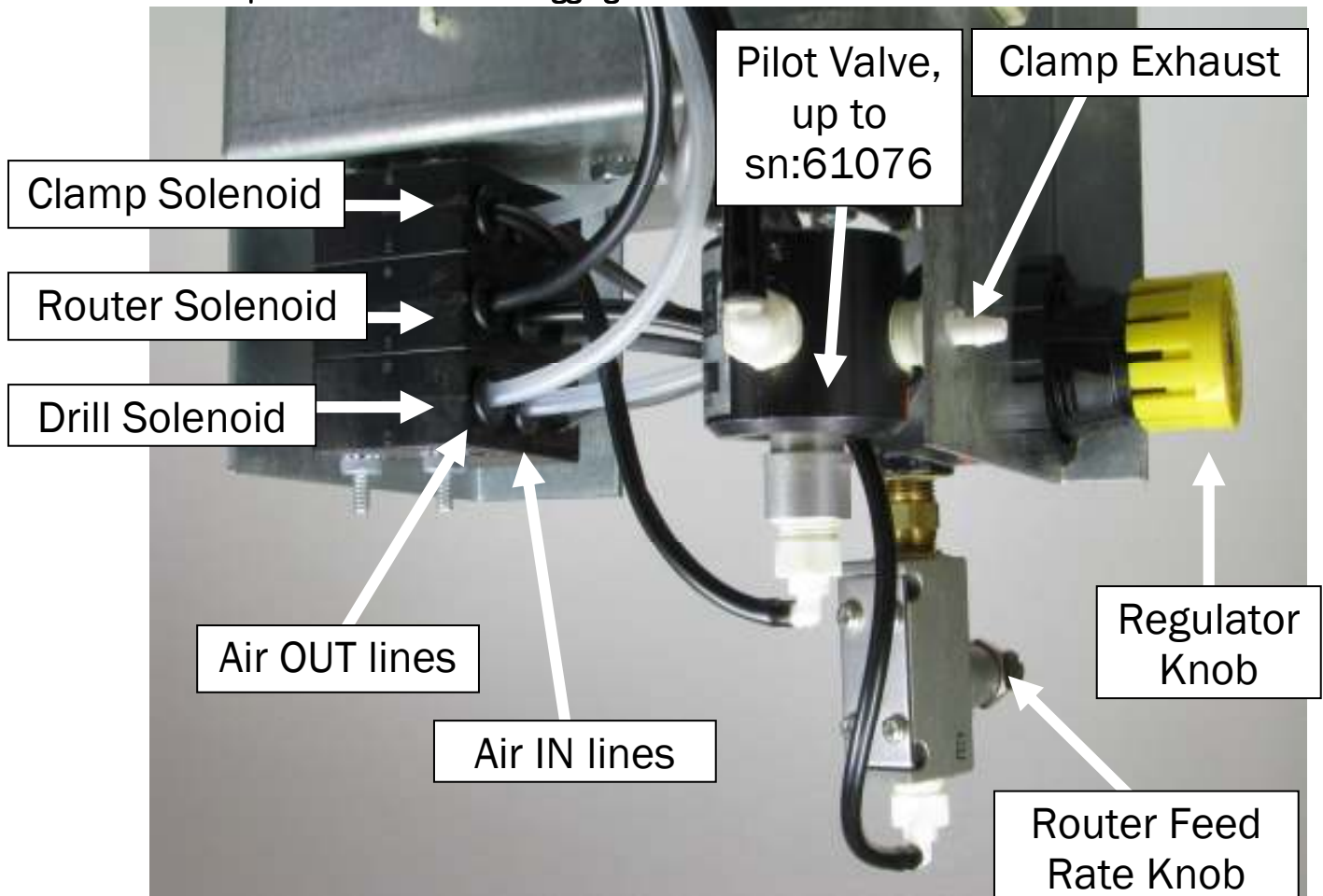

Figure 14



Castle TSM-21

Router Feed Rate Adjustment

21.32

The Router Feed Rate is adjustable to accommodate varying materials and/or bit types. If the Router Feed Rate is too fast, stock slippage, poor pocket quality, or dulled tooling may result. If the Router Feed Rate is too slow pocket burning and premature wear of the tooling may result.

As a rule of thumb – the harder the material, the slower the feed rate of the Router.

NOTE: If the Pressure Regulator has been adjusted, readjust the Router Feed Rate (if necessary) AFTER the Pressure Regulator setting has been finalized.

TO RESET THE ROUTER FEED RATE:

1. Locate the Feed Rate knob on the left of the case and fully loosen the Jamb Nut. **See fig. 16.**
2. Rotate the Feed Rate knob fully clockwise until it stops.
4. Rotate the Feed Rate knob 2 full revolutions counter-clockwise.
This setting is typical for hard woods.
5. Adjust the Feed Rate to your material by $\frac{1}{2}$ or $\frac{1}{4}$ turn at a time to obtain a clean, smooth pocket.
Counter-clockwise increases the Router Feed Rate. Clockwise decreases the Router Feed Rate.
6. Tighten the Jamb Nut after adjustments are finalized.

NOTE: If the Router comes up with the Feed rate knob turned fully clockwise, the Feed rate valve should be replaced.

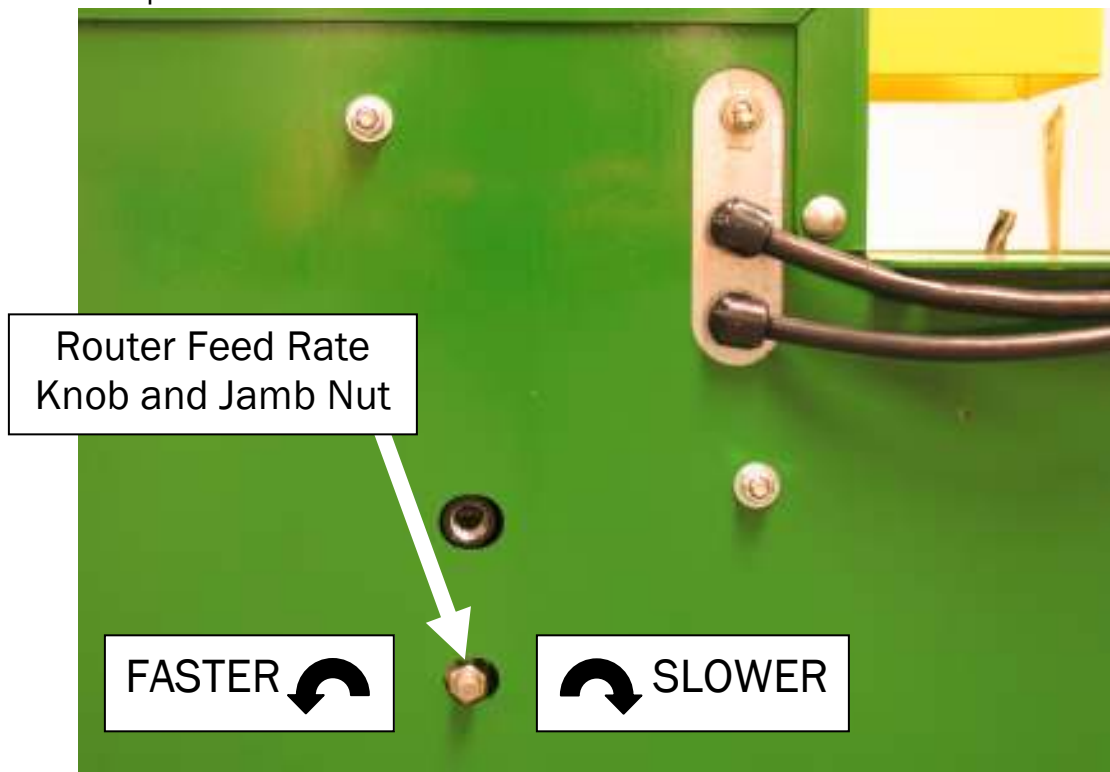

Figure 16



Castle TSM-21

Drill Motor Operation

21.40

The Drill Motor has its own power switch located on the motor body. This switch should always be in the ON position. Drill motor operation is controlled by the Power Switch on the machine.

Do not run the motor for more than two hours at a time.

The motor requires a ½ hour cool down period after each two hour period.

The Drill Motor is attached to the Motor Carriage by a bolt that is secured with a black T-Knob. This bolt may become loose due to vibration causing inconsistent pilot hole boring and/or frequently broken drill bits.

TIGHTENING THE DRILL MOTOR:

1. Open the rear door.
2. The Drill Motor is mounted on top of the yellow Motor Carriage. **See fig. 17**
3. Locate the Drill T-Knob on left side of the Motor Carriage.
4. Gently rock the Drill Motor as you tighten the T-Knob

REMOVING / INSTALLING THE DRILL MOTOR:

1. **Disconnect power and air from the machine.**
2. Unplug the motor.
3. With your left hand loosen the T-Knob until it releases the Drill Motor. Use your right hand to lift the motor back and then out the rear door.
4. When re-installing, make sure the motor mounting bolt aligns with the mounting hole at the top of the carriage. Make sure the drill's power cable is pointing down.
5. Tighten the black T-Knob onto the mounting bolt.
6. Manually rock the Motor Carriage toward the front of the machine and make sure that the Drill Bit cleanly fits through the hole on the face plate.

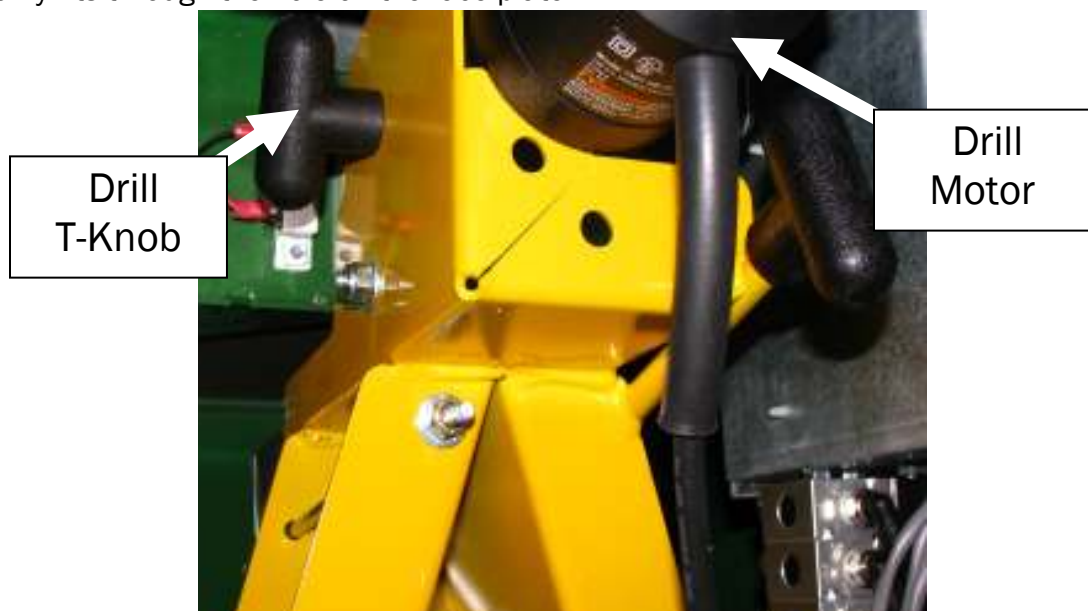

Figure 17

Continued...

21.40 Continued.

SERVICNG THE DRILL MOTOR:

1. The motor is warranted for one year from the purchase of the machine.
2. Warranty replacement and parts purchases can be handled by your nearest Porter Cable dealer/service center, or Castle.
3. Follow the instructions found in your Porter Cable manual on maintaining the motor. This includes information on keeping the motor clean and free of dust, maintaining the brushes and replacing the tooling.
4. The Drill Motor has two electrical brushes that should be periodically replaced.

NOTE: During assembly at Castle, the front housing of the drill motor is rotated 90 degrees to orient the power cord straight down relative to the T-Knob bolt hole. Replacement motors obtained through sources other than Castle may need to have the front housing rotated similarly.



Castle TSM-21

Drill Settings & Bit Depth

21.41

The TSM-21 is designed to handle many types and thicknesses of material. Depending on screw type and length, and the thickness of the material, the drill collet setting may need to be adjusted. If the drill bit appears blackened or burned it is spending too much time boring the Pilot Hole and may overheat and loosen in its shank

TESTING STEPS:

1. Hold the shank against a solid surface, and tap the end of the bit.
2. If the bit slides down into the shank AT ALL it needs to be replaced.
3. If the bit doesn't slide in the shank, hold the shank with pliers and with another pair of pliers, grip the bit BELOW THE FLUTE, just above where the bit joins the shank. Do not use excess grip pressure on the bit itself.
4. Twist the bit and shank in two, opposite directions

If the shank and the bit can twist independently, the bit should be replaced

To simplify tooling changes or settings, a Bit Gauge is included to record the depth setting most suitable for your purposes. **See fig. 18.** The Bit Gauge is inside the back door of the machine to the left of the router wrenches. Proper bit depth varies by application but as a rule of thumb - the drill depth only needs to be long enough to just penetrate the pocket.

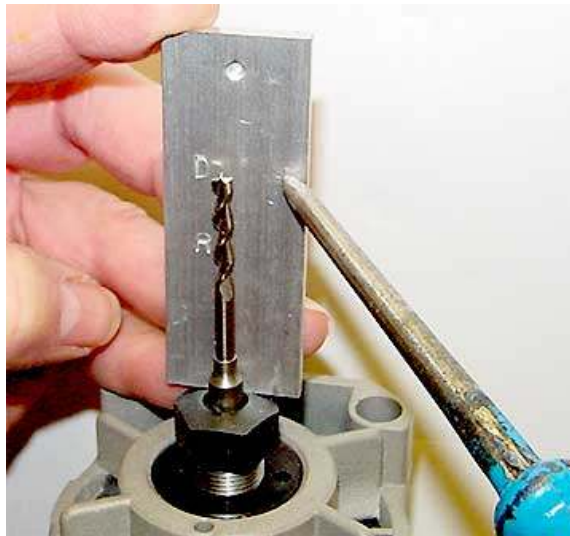

Figure 18

SETTING STEPS:

1. Set the gauge on top of the collet and use an awl to scratch a reference line in the soft aluminum where each bit should be. "D" for Drill and "R" for Router.
2. The plate has two sides that can be used settings for different processes in the shop.



Castle TSM-21

Drill Single Coil Bar Spring

21.42

The Bar Spring is located inside the top of the machine, above the Control Box. The Motor Carriage compresses this spring as it moves forward to drill the Pilot Hole. After the Pilot Hole is drilled, the Bar Spring provides the push to return the carriage to neutral position. If you push the carriage forward by hand it should “spring” back when released. If the carriage remains forward the Bar Spring may be loose or broken.

REPLACEMENT STEPS:

1. **Disconnect air and power from the machine.**
2. Remove the two carriage bolts that hold the Control Box to the machine. Leave the box hanging in place.
3. A small rectangular plate anchors the Bar Spring. Note how the spring slides between two bolts in this plate. Loosen the nuts and remove the old spring and slide in the replacement spring.
4. The short elbow at the end should face up toward the inside of the case top. Place a plastic cap on the tip of the elbow and apply a small amount of lubricant to the plastic cap to reduce friction resistance. **See fig. 19**
5. Make sure the Bar Spring is on the front side of the 3” carriage bolt and tighten the nuts.
6. Push the carriage forward by hand. The carriage should “spring” back when released.
7. Reinstall the Control Box and reconnect air and then power to the machine.

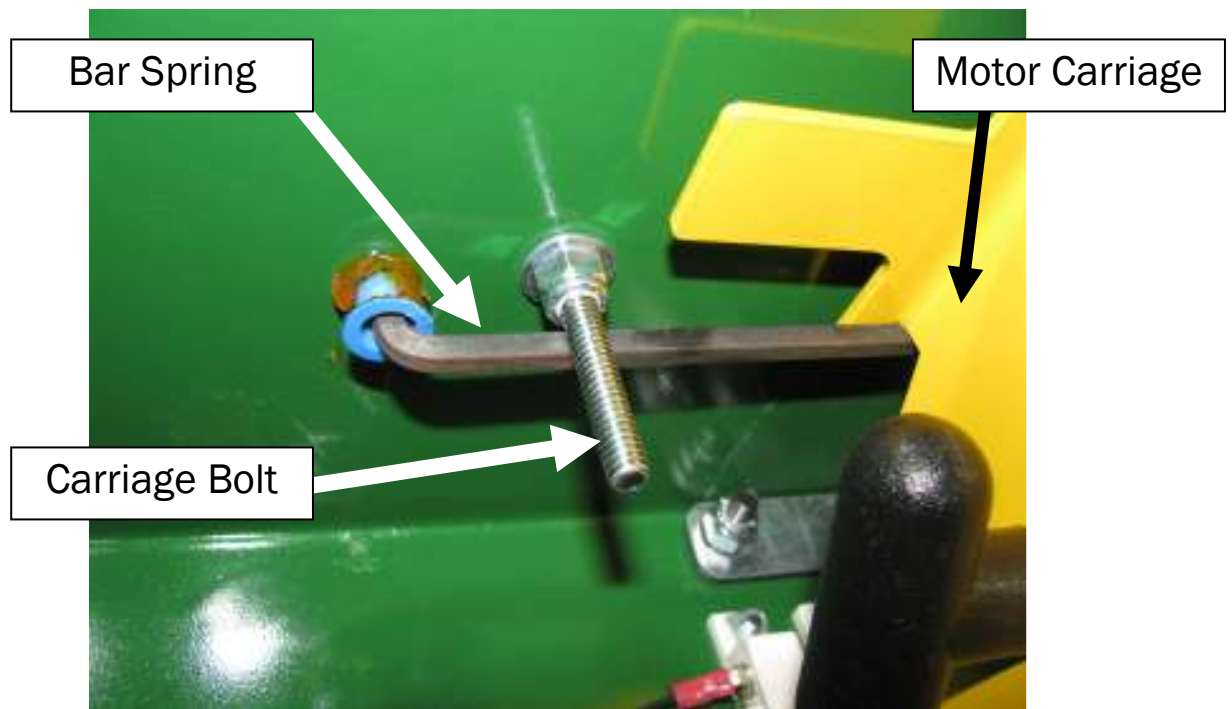

Figure 19



Castle TSM-21

Drill Stop Switch (NC)

21.43

The Drill Stop Switch consists of a magnetic reed switch (with wires) and a magnet (no wires). The switch is Normally CLOSED (NC) and OPENS at the end of the Pilot Hole cycle when the Motor Carriage breaks the magnetic field. The switch then signals both the Drill solenoid and Clamp solenoid to stop airflow, which allows the Drill to retract and Clamp to release.

If the Drill Stop Switch fails, or the magnetic field weakens or becomes misaligned, the machine will not sense the end of the drill cycle. The drill may stay forward in the Pilot Hole causing the cycle to stall or the clamp may extend but immediately release.

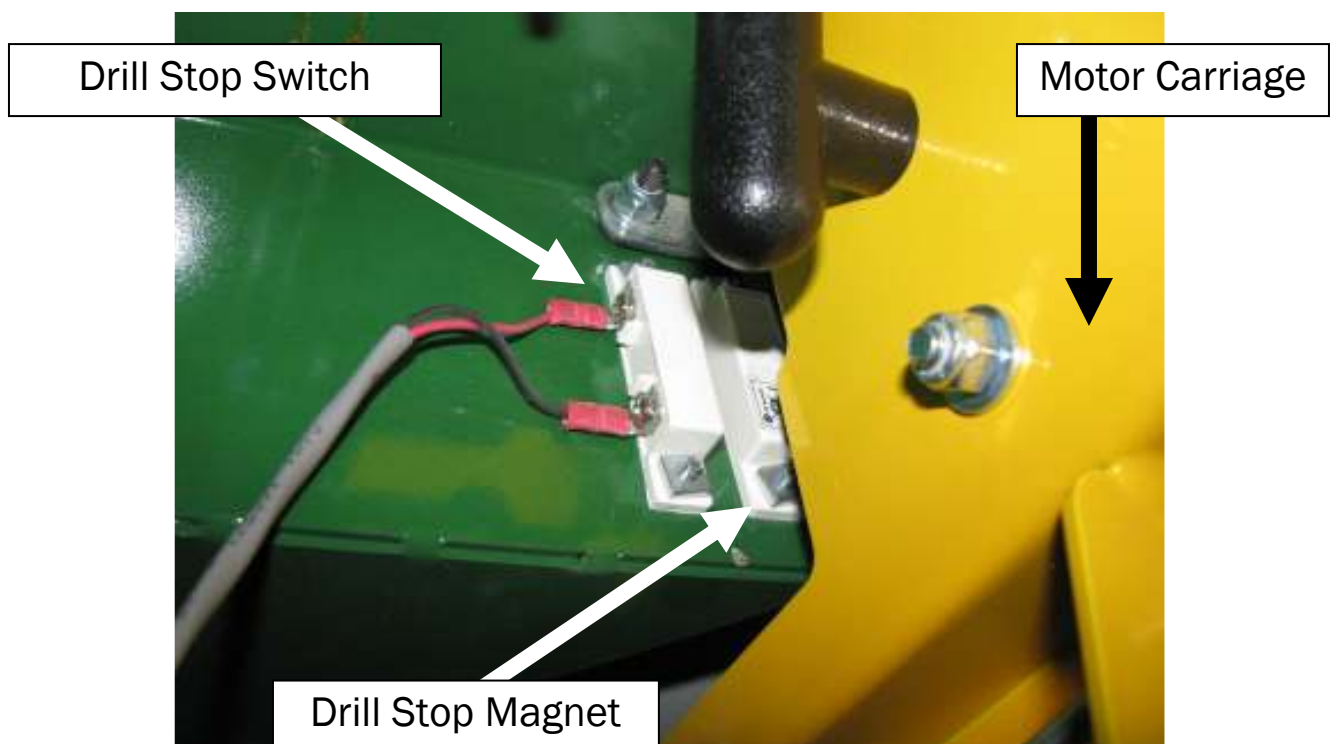

Figure 20

TESTING STEPS:

1. **Disconnect power and air from the machine.**
2. The Drill Stop Switch and magnet are located inside the machine on the back side of the Face Plate, slightly to the left of the Pilot Drill Hole. **See fig. 20**
3. Test for continuity across the terminals of the switch. The switch should be CLOSED with the Motor Carriage in neutral position.
4. If the switch measures OPEN while the Motor Carriage is in neutral position, adjust the magnet closer to the switch and repeat **step 3**.

Continued...

21.43 Continued

TESTING STEPS: (cont.)

5. Push the carriage forward until it makes contact against the Face Plate. The switch should now measure as OPEN. (A few kilo ohms of resistance are normal when the switch is OPEN.)
6. If the switch does not OPEN loosen the mounting nuts and adjust the magnet as far as possible from the reed switch, and repeat **step 5**.
7. If the switch continuously measures CLOSED regardless of how far away the magnet is, replace the switch assembly.
8. If the switch continuously measures OPEN regardless of how close the magnet is, replace the switch assembly.
9. If the switch needs to be replaced the laminate strip on the front of the machine may need to be removed to access the switch retaining screws. Pry the laminate free from the case with a sharpened putty knife. Contact Castle for a replacement laminate strip.



Castle TSM-21

Unclogging the Drill Solenoid

21.50

NOTE: All Solenoid Air Fittings are “Push In” connections. To remove an air line, push in the plastic or metal rim of the fitting and pull the air line out. To re-install, push the air line in until it meets resistance and then push in another $\frac{1}{2}$ "

The appearance of the solenoids may differ. See Appendix E, page 51 for equivalent illustration for machines SN: 61076 and above.

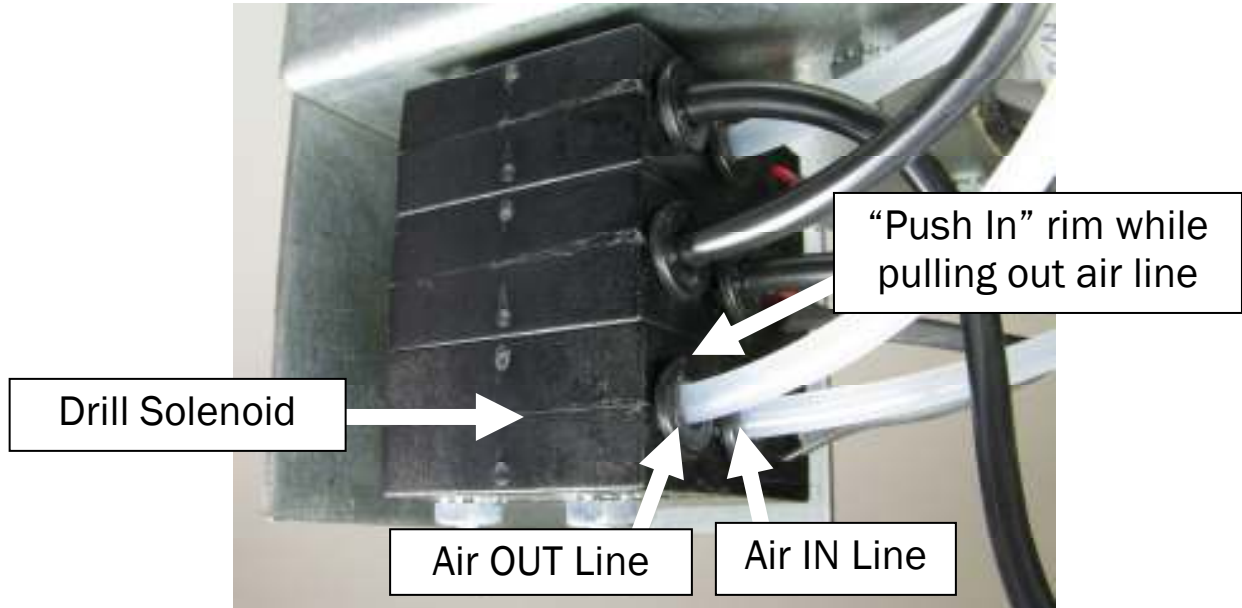

Figure 21

1. **Disconnect power and air from the machine.** Remove both air lines from the Drill Solenoid. **See fig. 21.**
2. Reconnect air to the machine and the “Air In” line will now be flowing with about 85 PSI. Use the “Air In” line to clean out both open ports on the Drill solenoid.
3. Disconnect the air supply and reinsert the air line that was flowing, back into the “Air In” port of the solenoid valve.
4. Un-plug or turn off both routers.
5. Connect power and air to the machine, and turn the Power Switch ON.
6. Put two boards on opposite sides of the slot on the Table Top, press them against the Safety Buttons, and depress the Foot Pedal. After the Router Stroke, air should be flowing from the “Air Out” port of the drill valve.
7. Turn the Power Switch OFF and repeat **steps 5 and 6** several times to ensure all contaminants are expelled, then insert the remaining hose back into the “Air Out” port of the Drill valve.
8. Turn the routers back on and cut a test pocket.

If this procedure does not correct the problem, the Drill Solenoid will need to be replaced.

Refer to Procedure 21.91, “Replacing Solenoids” page 47-48



Castle TSM-21

Drill Solenoid Check

21.51

The Drill Solenoid controls air pressure to the Drive Cylinder, which provides the forward motion of the Drill's boring stroke. If the Drill Solenoid has stuck open, the drill will extend as soon as air is attached to the machine, regardless of whether the power is turned on. If the Drill Solenoid is clogged the Drill may not start or complete the pilot hole.

The appearance of the solenoids may differ. See Appendix E, page 51 for equivalent illustration for machines SN: 61076 and above.

TESTING STEPS:

1. Detach the air supply from the machine.
2. Swap the "Air Out" lines between the Drill Solenoid and the Router Solenoid. **See fig. 22**
3. Attach the air supply to the machine and see if the router now extends instead of the drill. If it does then the Drill Solenoid has stuck open.
4. Swap the air lines back again.
5. **Perform procedure 21.50 – “Unclogging the Drill Solenoid”.**

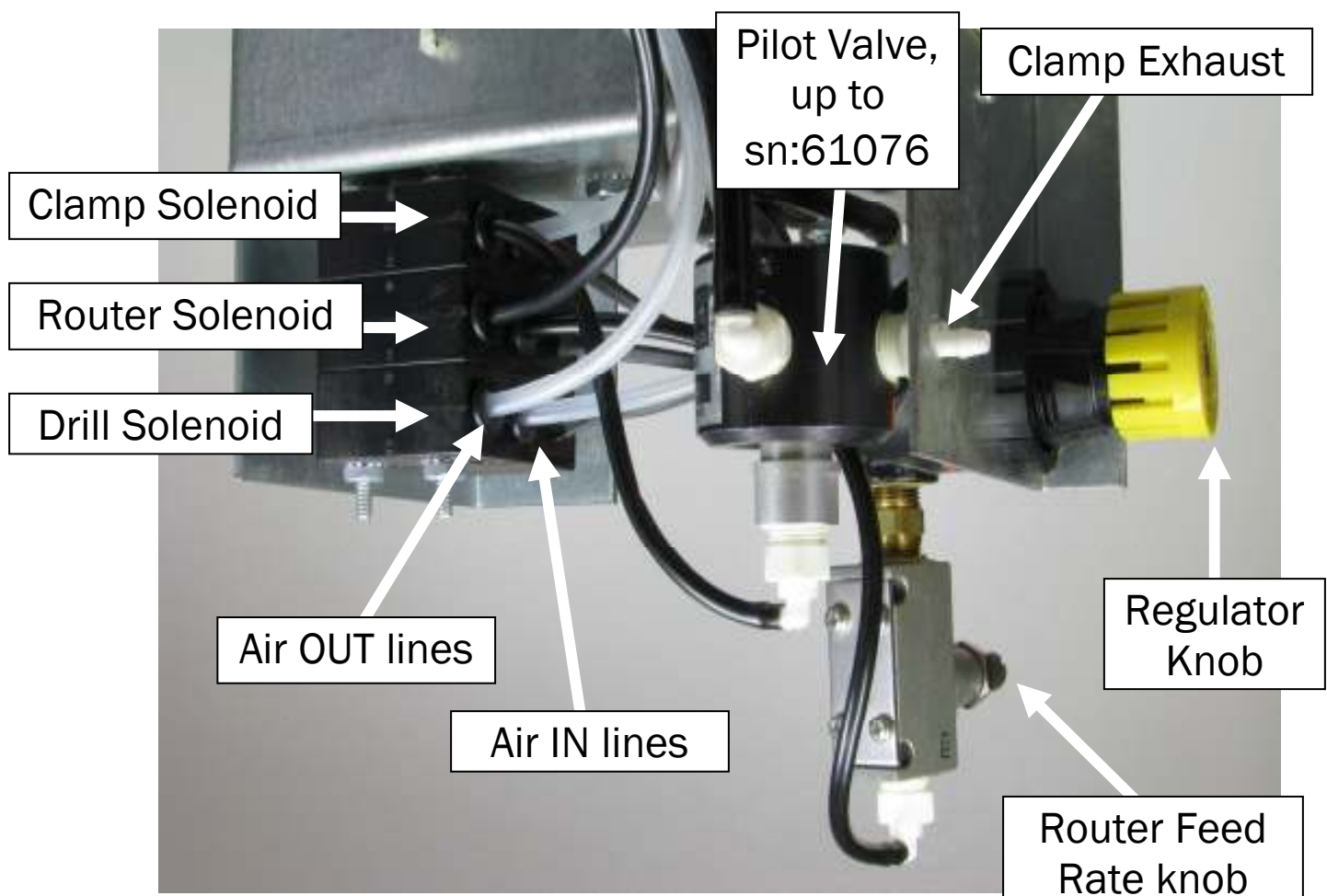

Figure 22



Castle TSM-21

Drive Cylinder, Check

21.60

The Drive Cylinder provides the forward and back stroke to the Motor Carriage for the Router and Pilot Drill phases. If the cylinder fails or if the air lines become clogged, the machine may not complete one or both of these phases. Occasionally the cylinder seal may need to be reseated. Do this by rocking the carriage back and fourth by hand through the rear door. It is normal to detect a “puff” of air at the Drive Cylinder mounted SQE (Super Quick Exhaust) valves when rocking the carriage. Machines with Serial numbers after 62480, do not have SQE valves, therefore, it is normal to detect a “puff” of air at the exhaust ports of the Router and Drill Solenoids when manually rocking the carriage.

TO DETECT A BAD CYLINDER SEAL:

If the cylinder seal is dry, damaged, or not seated properly, air may bypass the cylinder piston and constantly exhaust out the SQE on the opposite end of the cylinder (often accompanied by an audible hissing sound). Machines with Serial numbers after 62480 do not have SQE valves. Inspect for leaking air at the exhaust ports of the Router and Drill Solenoids.

1. **Un-plug or turn off both routers.**
2. Connect power and air to the machine, and turn the Power Switch ON.
3. Place a piece of scrap wood against the Safety Buttons and depress the Foot Pedal to induce a stall during the router stroke.
4. Listen for constant hissing and feel for leaking air at the open barbs on the SQE valves (or at the exhaust ports of the Rout Solenoid and the Drill Solenoid). **See fig. 24**
5. Cycle the machine a few more times to see if the situation can be repeated.
6. If the stalled Drive Cylinder consistently leaks air, the cylinder must be replaced.

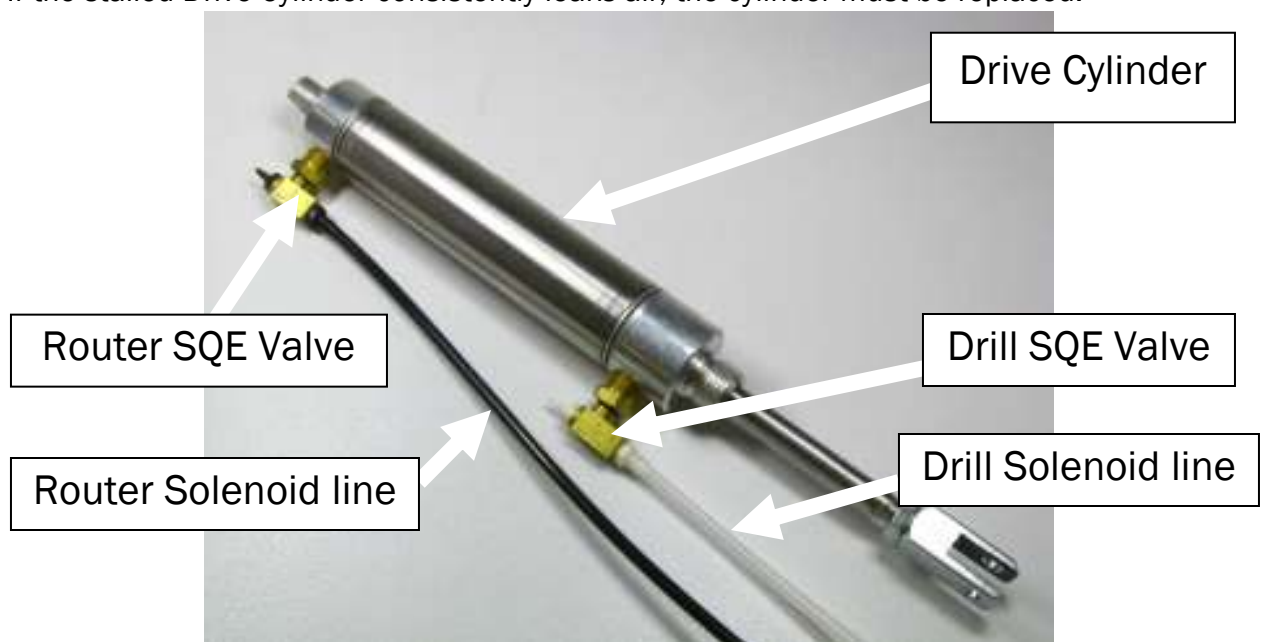

Figure 24

Continued...

21.60 Continued

OPTIONAL STEPS:

Sometimes an air leak may be more noticeable during the Drill stroke.

7. **Un-plug or turn off only the Drill motor.**
8. Connect power and air to the machine, and turn the Power Switch ON.
9. Place a piece of scrap wood against the Safety Buttons and depress the Foot Pedal in order to start a normal cycle. The router will cut a normal pocket, but will stall during the Drill stroke.
10. Leave the Power Switch ON. Now un-plug or turn off the Router motor.
11. Listen for constant hissing and feel for leaking air at the open barbs on the SQE valves (or at the exhaust valves of the Router and the Drill Solenoids). **See fig. 24.**
12. Cycle the machine a few more times to see if the situation can be repeated.
13. If the stalled Drive Cylinder consistently leaks air, the cylinder must be replaced.



Castle TSM-21

Drive Cylinder SQE (Super Quick Exhaust) Valves

21.61

The Drive Cylinder provides the forward and back stroke to the Motor Carriage for the Router and Pilot Drill phases of the cycle. If the Drive Cylinder mounted SQE (Super Quick Exhaust) valves fail or become clogged, the machine may not complete one or both of these phases. Test by rocking the carriage back and fourth by hand through the rear door. You should detect a “puff” of air at the SQE valves when manually rocking the carriage. Machines with serial numbers after 62480, do not have Drive Cylinder mounted SQE valves, therefore, it is normal to detect a “puff” of air at the exhaust ports of the Router and Drill Solenoids when manually rocking the carriage.

NOTE: All Solenoid Air Fittings are “Push In” connections. To remove an air line, push in the plastic or metal rim of the fitting and pull the air line out. To re-install, push the air line in until it meets resistance and then push in another 1/2”

The appearance of the solenoids may differ. See Appendix E, page 51 for equivalent illustration for machines SN: 61076 and above.

TESTING STEPS:

1. Disconnect the “Air Out” lines from the Router and Drill Solenoids. See fig. 25. The other end of the lines should remain attached to the Drive Cylinder SQE valves. See fig. 26.

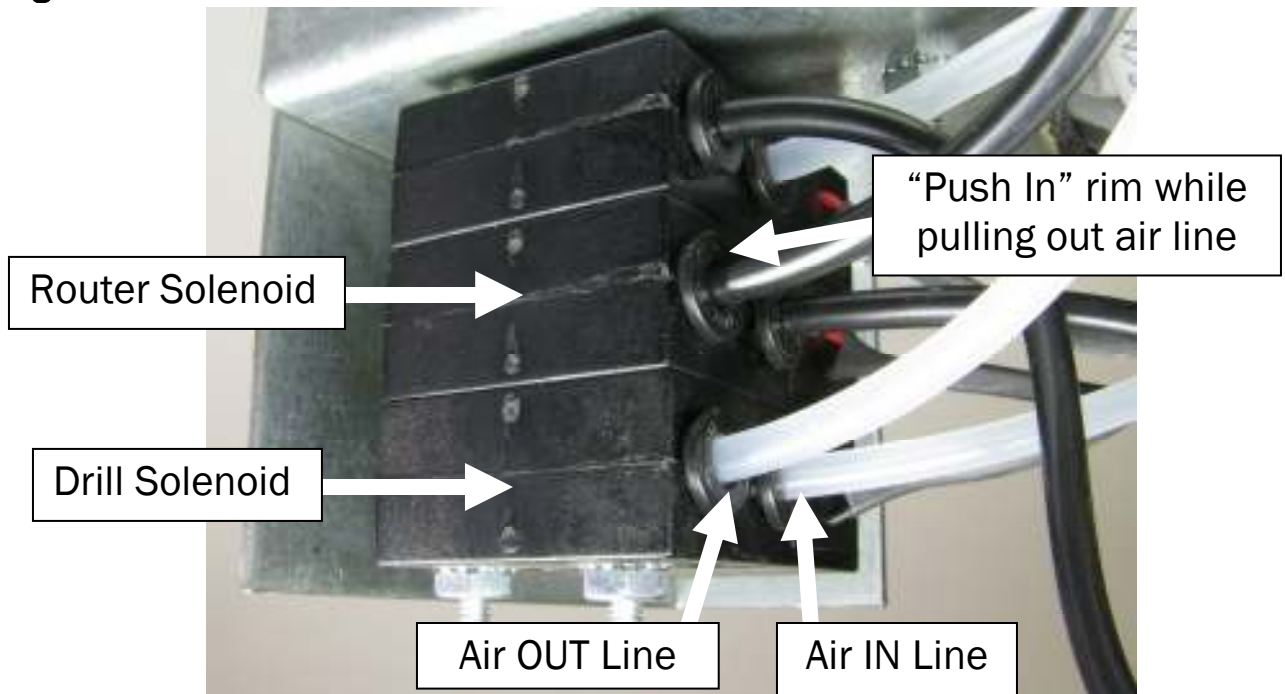

Figure 25

Continued...

21.61 Continued

2. Un-plug or turn off both routers
3. Place two boards on opposite sides of the slot on the Table Top, press them against the Safety Buttons, and depress the Foot Pedal.
4. At the rear door, manually simulate the Router and Drill strokes by first pulling, then pushing the yellow Motor Carriage.
5. Make sure air escapes first from the Router Solenoid and then from the Drill Solenoid before the manual cycle is complete.
6. Reconnect the “Air Out” lines to the Router and Drill Solenoids. **See fig. 25.**
7. Disconnect the “Air Out” lines at the Drive Cylinder SQE valves. **See fig. 26.**
8. Repeat Steps 3 and 4.
9. The air lines should exhaust air as you manually cycle. Make sure air escapes first from the black Router Solenoid line and then from the translucent Drill Solenoid line before the manual cycle is complete.
10. This should clear any blockage from the air lines and Drive Cylinder SQEs
11. Reconnect the air lines to the Drive Cylinder as shown in **figure 26.**
12. Turn the routers back on and cut a test pocket.

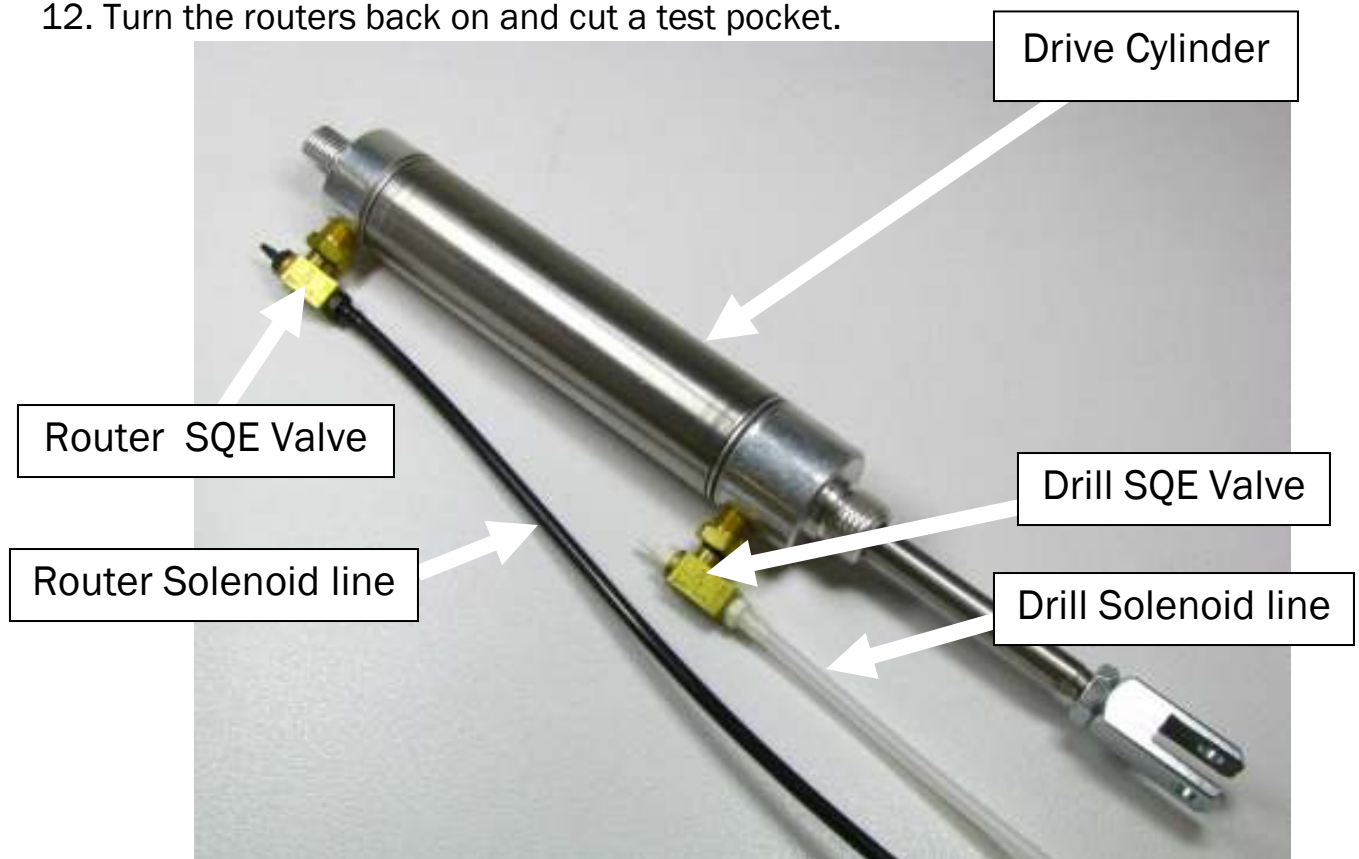

Figure 26



Castle TSM-21

Pilot Hole Alignment

21.72

The Pilot Hole should be drilled in the center of the deepest part of the pocket.

ADJUSTMENT STEPS:

1. From the rear door, locate the hex nut immediately below the Drill T-Knob on the upper left side of the Motor Carriage. **See fig. 27.**
2. Tightening the hex nut moves the drill tip left relative to the operator. Adjust accordingly.

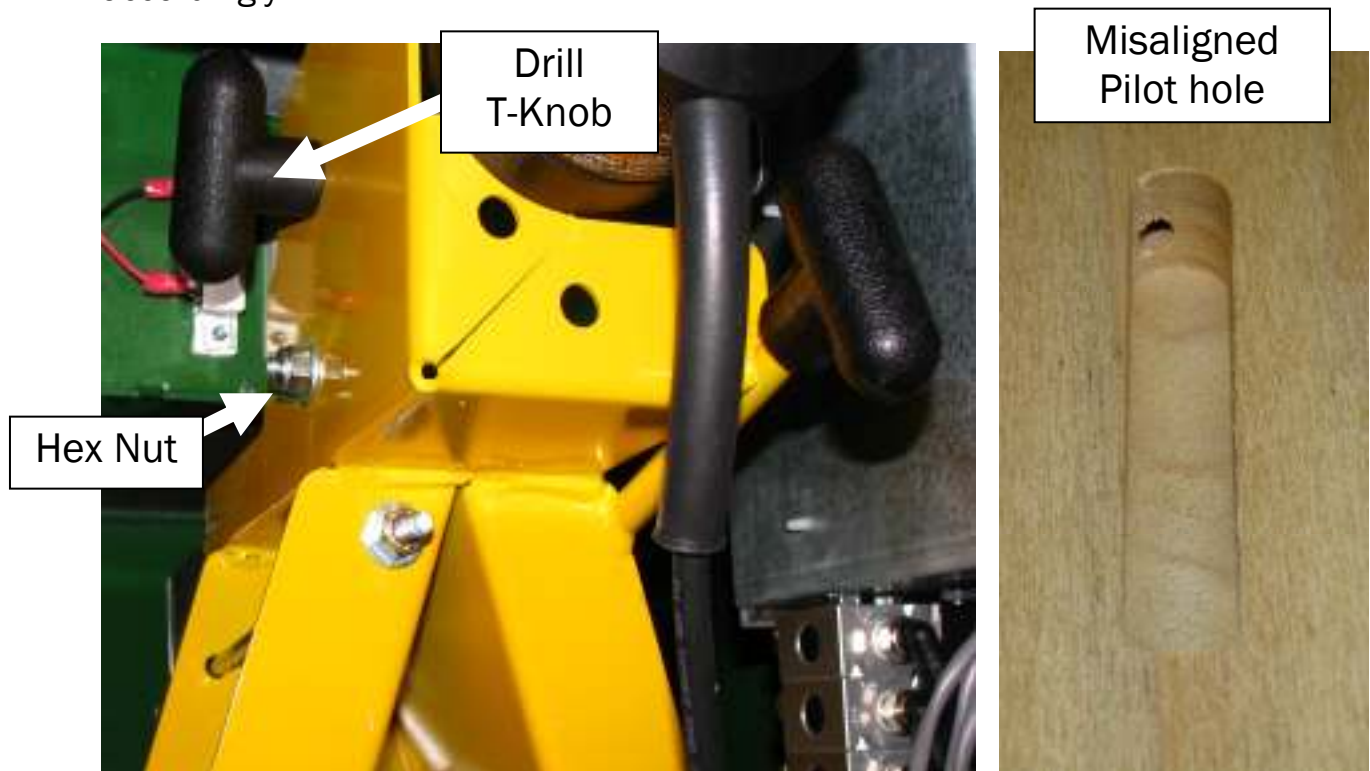

Figure 27



Castle TSM-21

Foot Switch (NO)

21.80

The Foot Switch is located in the Foot Pedal. At rest, the Foot Switch is normally OPEN. It works in conjunction with the Safety Buttons/ Safety Switch. Closing the Foot Switch (while simultaneously closing the Safety Switch) starts the machine cycle.

TESTING STEPS:

1. Turn the Power Switch OFF.
2. Remove the two small screws that hold the Pedal to the yellow guard.
3. Use a flat tip screwdriver to pry the Pedal free from the guard. It is secured by silicone caulk.
4. Use a flat or Phillips screwdriver to remove the two screws on the sides of the pedal and remove the top. **See fig. 28.**
5. Test for continuity at the wired connections with the switch still in the pedal.
6. Without depressing the Spring Plate the switch should read OPEN. With the spring plate depressed, the switch should read CLOSED. Note: The switch is wired at the COM and NC terminals because the Spring Plate depresses the button on the switch at rest, holding the switch OPEN.
7. If the switch fails this test it must be replaced. Remove the two remaining Phillips screws through the switch to remove it from the Foot Pedal.

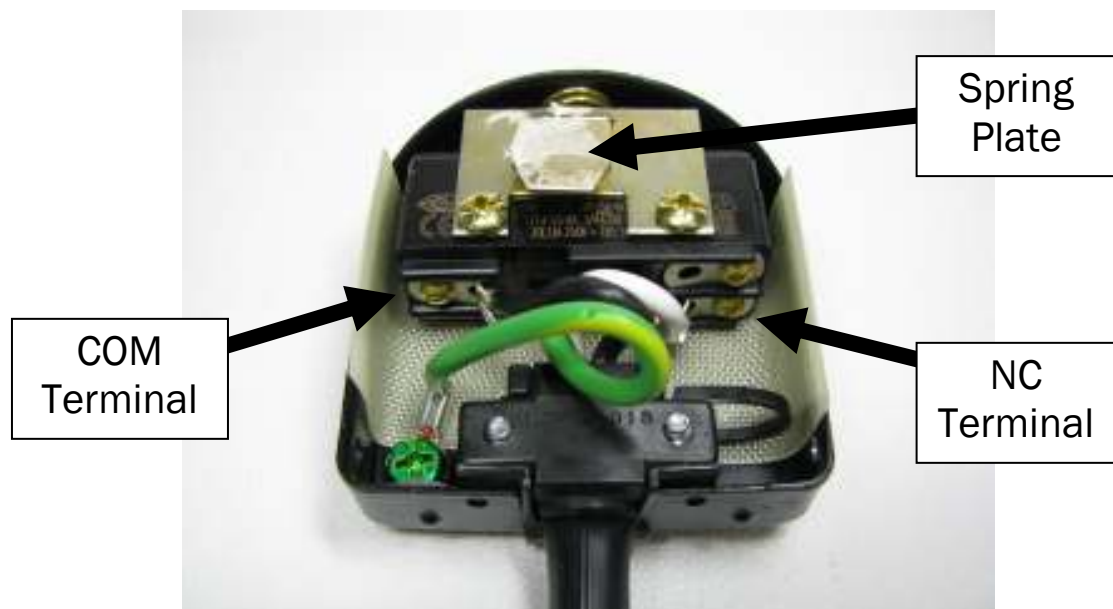

Figure 28



Castle TSM-21

Resetting the Machine

21.81

If the Power Switch is ON and the footswitch is pressed before the air supply is attached, the machine will begin to cycle as soon as the air is attached. This can result in the router bit becoming jammed against the Clamp Foot.

RESET STEPS:

1. Turn the Power Switch OFF. (This allows the solenoids to reset.)
2. Detach the air supply. (This allows the cylinders to reset)
3. Reattach the air supply.
4. Turn the Power Switch ON.



Castle TSM-21

Safety Switch / Safety Buttons (NO)

21.82

The Safety Switch consists of a reed switch (with wires) and a magnet (no wires). It is normally OPEN (NO) to prevent operation and CLOSSES when the Safety Buttons move the Safety Blade between the switch and the magnet. If the switch fails or the magnetic field weakens or becomes misaligned, the machine will not correctly detect if a cycle may begin or not. The cycle might not begin although wood is in place, or the cycle might begin with no wood in place.

TESTING STEPS:

1. **Disconnect power and air from the machine.**
2. The reed switch and magnet are mounted on the case top to the right of the Drill Motor.
See fig. 29.
3. Test for continuity at the terminals of the switch with the Safety Blade resting between the switch and the magnet. The switch should measure as OPEN.
4. If the switch measures CLOSED make sure the blade is resting squarely between the switch and magnet. Otherwise the distance between the switch and magnet may need to be increased by $\frac{1}{16}$ ".
5. When pressing the Safety Buttons, the switch should measure CLOSED. If the switch measures OPEN, the distance between the switch and magnet may need to be decreased by $\frac{1}{16}$ ".
6. If the switch will not change from OPEN to CLOSED when the Safety Blade is raised despite adjustment, replace the switch and the magnet.

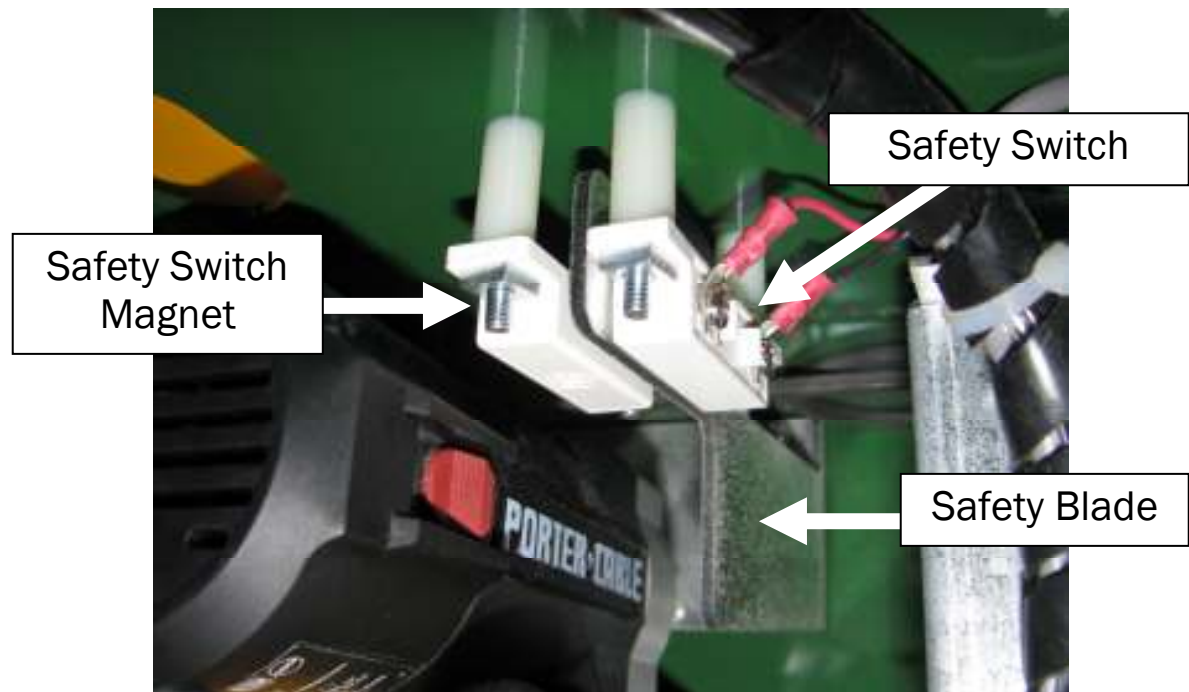

Figure 29



Castle TSM-21

Tooling Check & Replacement

21.83

Router and Drill bits wear over time and periodically need replacement. Selecting the appropriate bits and maintaining the proper operating speed for your application will maximize bit life. Too slow an operating speed can burn bits. Too fast an operating speed can break drill bits.

ROUTER:

1. **Disconnect power and air from the machine.**
2. Open the rear door and unplug both motors.
3. To the right of the Drill Motor is the Router T-Knob that tightens a large U-Bolt holding the Router Motor in place. **See fig. 30**
4. With your right hand loosen the Router T-Knob a few turns to provide enough slack to drop the Router Motor down into your left hand and then out the rear door.
- 4A. **ALTERNATE METHOD: Remove the four bolts and nuts attaching the work top and remove the work top for access to the router.**
5. Replace the bit. A Bit Gauge is provided to record your preferred Router Bit Height. Once a preferred setting is selected, mark or scribe your settings on the aluminum plate. ("R" Router) **See fig. 31.**
6. When re-installing, make sure the motor face is pushed up to seat flush with the tabs on the yellow carriage (if unsure, remove table top to confirm location).
7. Tighten the black T-Knob onto the U-Bolt. When the motor has been fully secured by the U-Bolt you might observe that the motor face is no longer flush with the yellow carriage tabs. That's OK.
8. Manually rock the Motor Carriage toward the rear of the machine and make sure that the router bit cleanly fits in the slot on the table top.

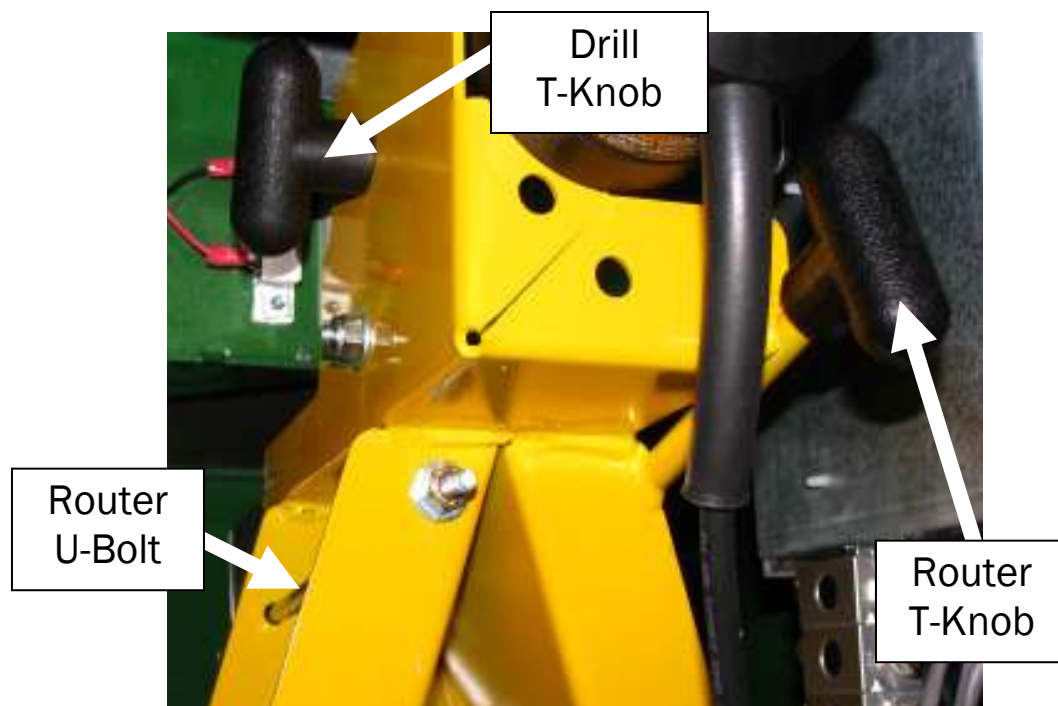

Figure 30

Continued...

21.83 Continued

DRILL:

1. **Disconnect power and air from the machine.**
2. Open the rear door and locate the Drill Motor at the top of the Motor Carriage. Just to the left is the Drill T-Knob that tightens a bolt holding the Motor in place. **See fig. 30.**
3. Unplug the motor.
4. With your left hand loosen the T-Knob until it releases the Drill Motor. Use your right hand to lift the motor back and then out the rear door.
5. Replace the bit. A Bit Gauge is provided to record your preferred Drill Bit Extension. Once a preferred setting is selected, mark or scribe your settings on the aluminum plate. ("D" Drill) **See fig. 31.**
6. When re-installing, make sure the Drill's power cable is pointing down.
7. Tighten the Drill T-Knob onto the mounting bolt.
8. Manually rock the Motor Carriage toward the front of the machine and make sure that the Drill Bit cleanly fits through the hole on the face plate.

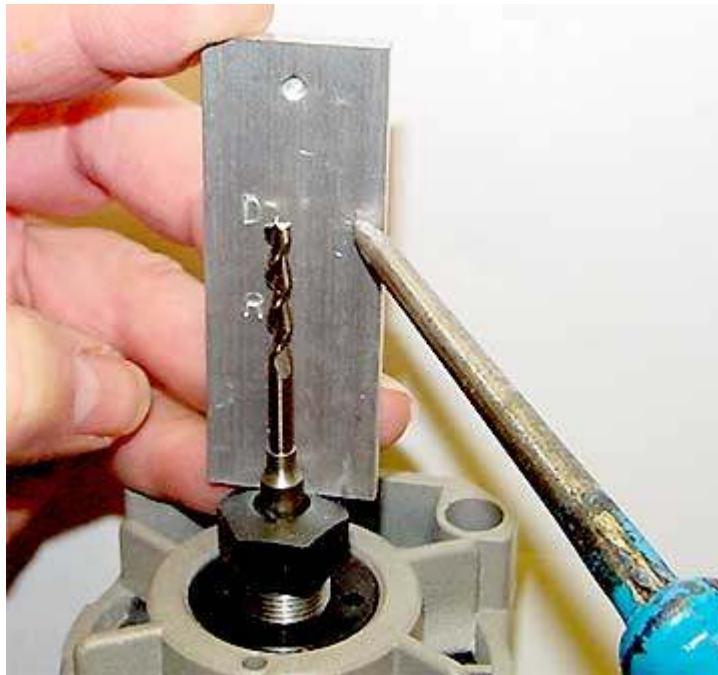

Figure 31



Castle TSM-21

Air Pressure Regulator, Setting

21.90

The Pressure Regulator determines Drill Feed Rate, clamping pressure, and overall speed of the machine. The factory setting is approximately 85 PSI. and should be checked periodically or when machine performance becomes rough or too slow. Cycles that are too slow can burn bits and cause drill bit separation at the shank. Cycles that are too fast can cause drill bits to break or to cut over-sized holes.

NOTE: It's extremely important that a minimum 85 PSI be provided from your compressor. Operating pressure can be especially affected by other machines that share the same air line as your TSM-21.

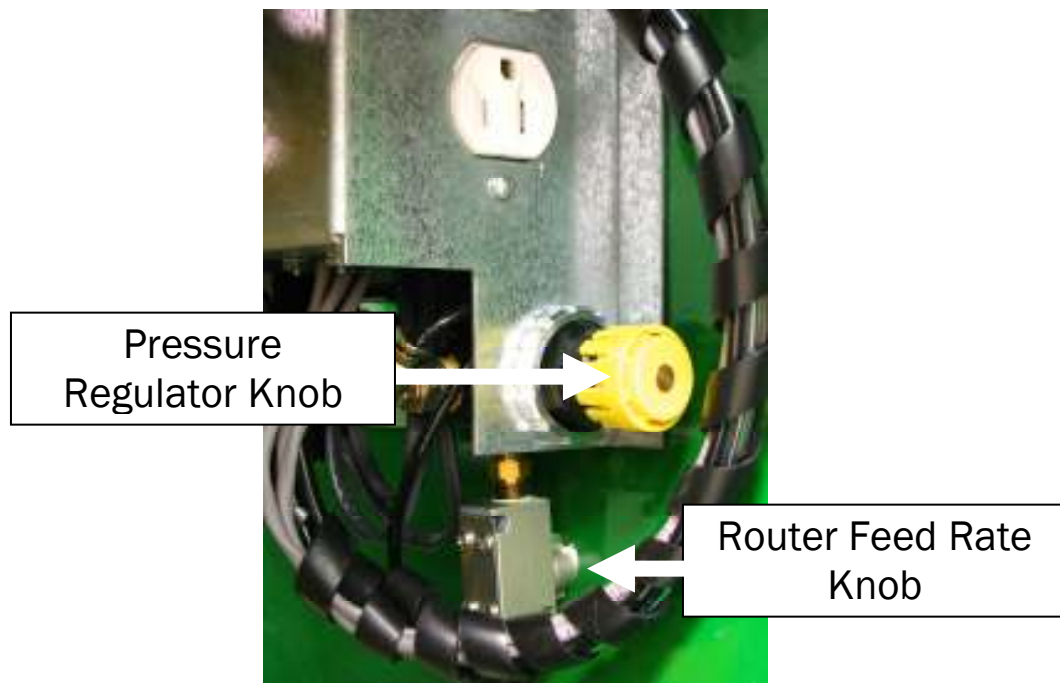

Figure 32

TO RESET THE AIR PRESSURE REGULATOR:

1. Open the rear door and locate the Pressure Regulator mounted to the Control Box. **See fig. 32.**
2. Pull out the Click-collar on the Regulator knob to unlock it.
3. Turn the knob fully counter-clockwise until it stops
4. Use a marker pen to make a reference point on the knob then turn it 6 full clockwise rotations. This process will set the pressure to approximately 85 PSI.
5. Cut test pockets and adjust slightly more or less than 6 turns until the appropriate operational speed is reached. **NEVER EXCEED 7 FULL ROTATIONS.**
6. Push in the click-collar on the Regulator knob to lock it.

NOTE: If the Pressure Regulator has been adjusted, the Router Feed Rate may need re-adjustment after the Pressure Regulator setting has been finalized. **See Procedure 21.32**



Castle TSM-21

Replacing Solenoid Valves

21.91

To replace a solenoid valve, follow the steps below.

STEPS:

1. Disconnect power and air from the machine.
2. Disconnect the Router and Drill power cords from the AC outlet.
3. Remove the two carriage bolts that hold the Control Box to the machine and pull the box partially out the rear door. **See fig. 33.**

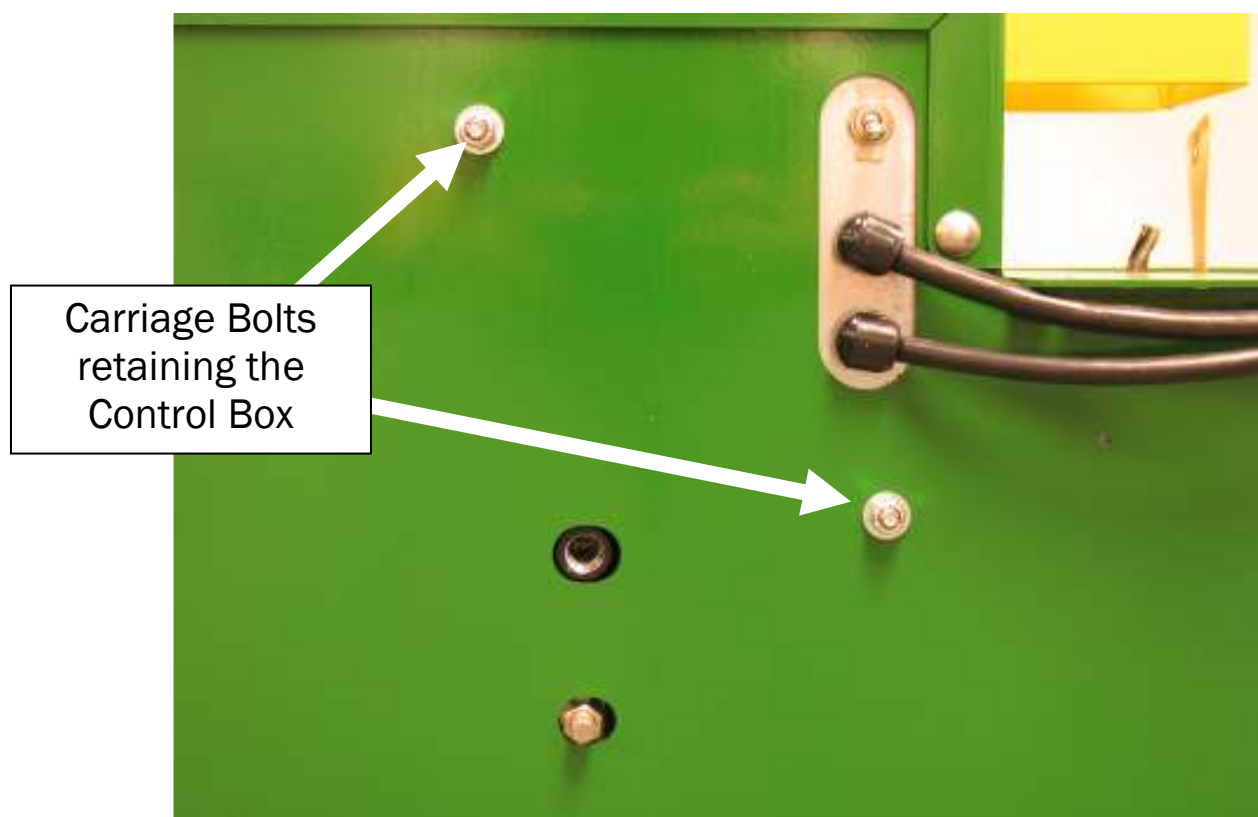

Figure 33

Continued...

21.91 Continued

4. Label the three solenoids and remove the two hex nuts and lock washers that hold the solenoids together. **See fig. 34**

The appearance of the solenoids may differ. See Appendix E, page 51 for equivalent illustration for machines SN: 61076 and above.

5. Label then disconnect the "Air In" and "Air Out" lines of the solenoid to be replaced.
For SN: 61076 and above, label then disconnect the air lines then remove the pneumatic fittings from the old solenoid with a 7/16" wrench.
(Note: Only disconnect the air lines of the solenoid you are replacing).

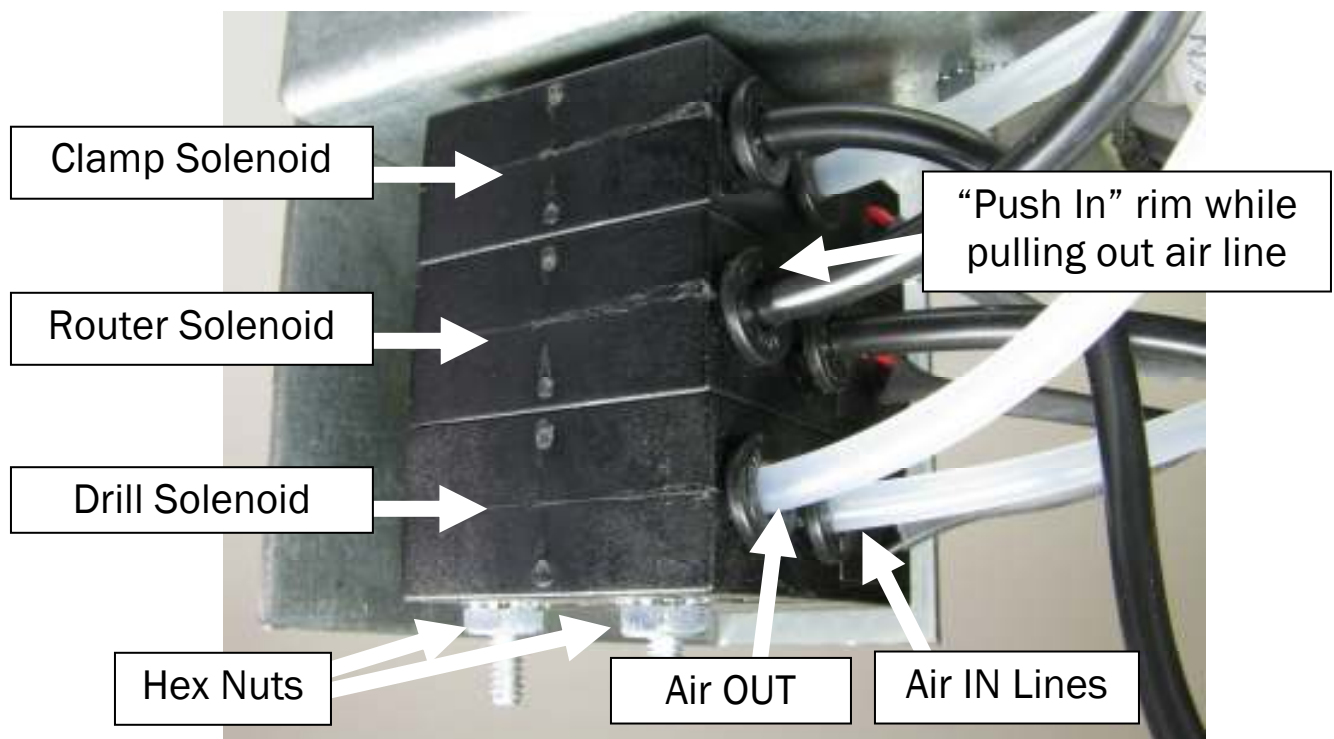

Figure 34

6. Cut the electrical wires to the solenoid being replaced leaving an inch on the old solenoid.
7. Splice in and insulate the wires of the new solenoid, NOTE: polarity is not important.
8. Reconnect the "Air In" and "Air Out" lines.
For SN: 61076 and above, install the pneumatic fittings with a 7/16" wrench: Port #1 = Air IN, Port #2 = Air OUT, Port #3 = Exhaust muffler, then reconnect the air lines.
9. Reassemble the solenoids in a stack and tighten the hex nuts and lock washers.
Do not over tighten the hex nuts.
10. Reinstall the Control Box using the carriage bolts.
11. Reconnect air and then power to the machine.



Castle TSM-21

Attaching Air Supply

21.92

An air supply with a MINIMUM of 80 PSI must be provided for proper operation of the TSM-21 Pocket Machine.

1. From the operator's position the air inlet is the $\frac{1}{4}$ " NPT fitting located on the left side.
2. Use proper thread sealant and install desired attachment method.
3. CASTLE recommends the use of a secondary filter method directly in line with the supply at the machine.
4. Do not use lubricants or connect a lubricator to the machine.

Do not turn the machine on without air attached.



Castle TSM-21

Appendix A.

Machine Safety

21.96

General Safety Rules for Machine Operators

- Read the Operator Manual carefully before operating this machine. It contains important information and warnings concerning the use and operation of this machine. Improper use of this machine may result in serious injury and/or damage to property.
- Use Caution when using this machine. Only trained operators should use this machine, or be within ten feet when the machine is in operation.
- Always wear protective eyewear and hearing protection when operating or standing near an operating machine.
- Be certain the machine is properly grounded before operating it.
- Operate this machine only when the doors and covers are in their proper position.
- Keep all body parts away from the moving parts of this machine whether it is in operation or at rest.
- Do not place hands or fingers between the work piece and the clamp or near the cutters at any time.
- Do not wear gloves or loose clothing (such as sweater, jackets, or jewelry) when operating or standing near an operating machine.
- Keep both hands on the work piece when initiating a Pocket Cycle on this machine.
- Before attempting adjustments, maintenance, or repair, STOP this machine and disconnect it from the compressed air supply and AC mains power. Wait for all motion to stop. Failure to disconnect this machine from its air supply and power, or failure to wait for all motion to stop could result in electrocution or injury. When attempting any kind of electrical repair work, disconnect the machine from AC mains power.
- Always keep the area around the machine clean and uncluttered. Poor housekeeping could result in slips, falls or other injuries.



Castle TSM-21

Appendix B

Wiring Diagram

21.84

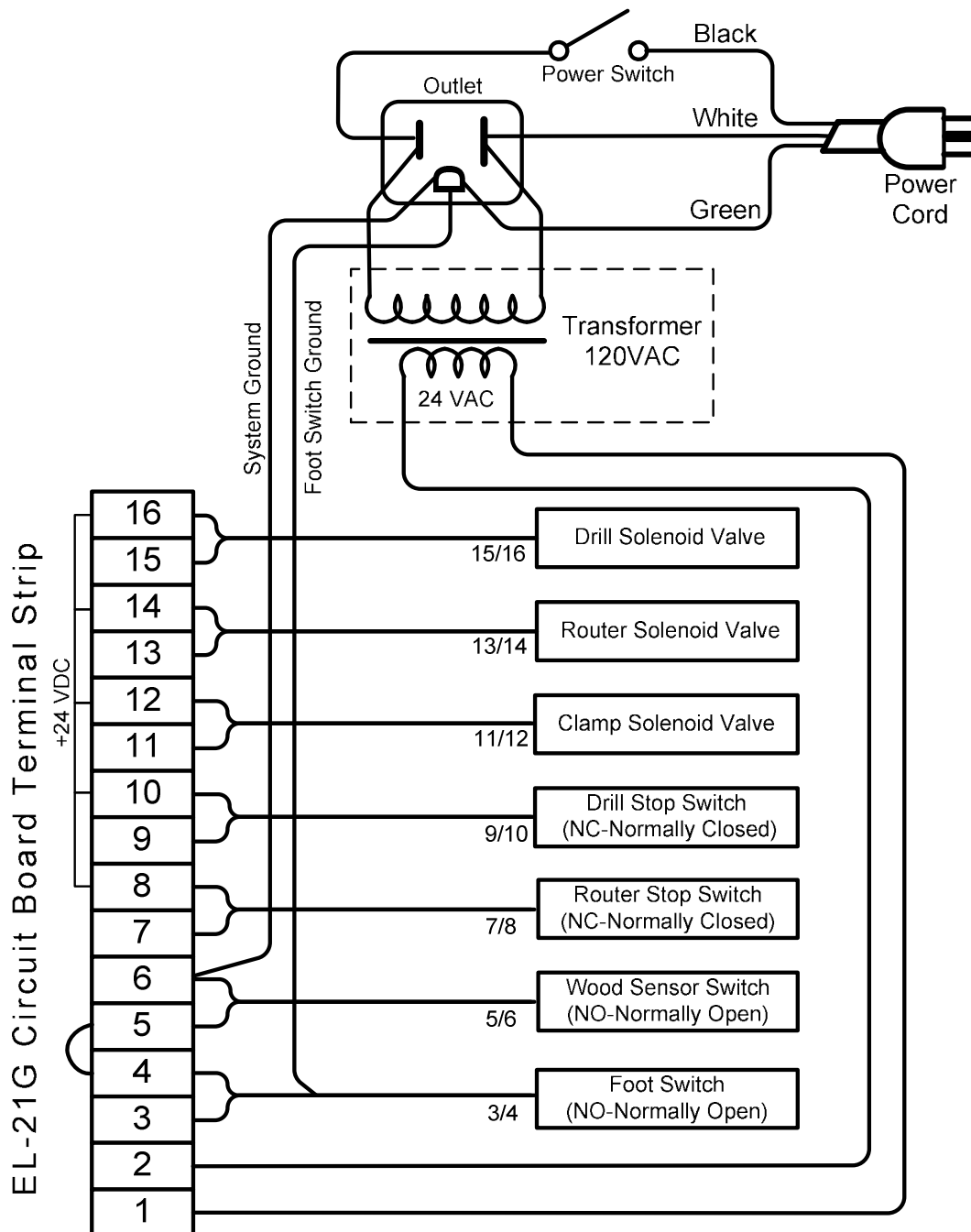



Castle TSM-21

Appendix C

Control Box Works

21.93

Up to SN: 61036

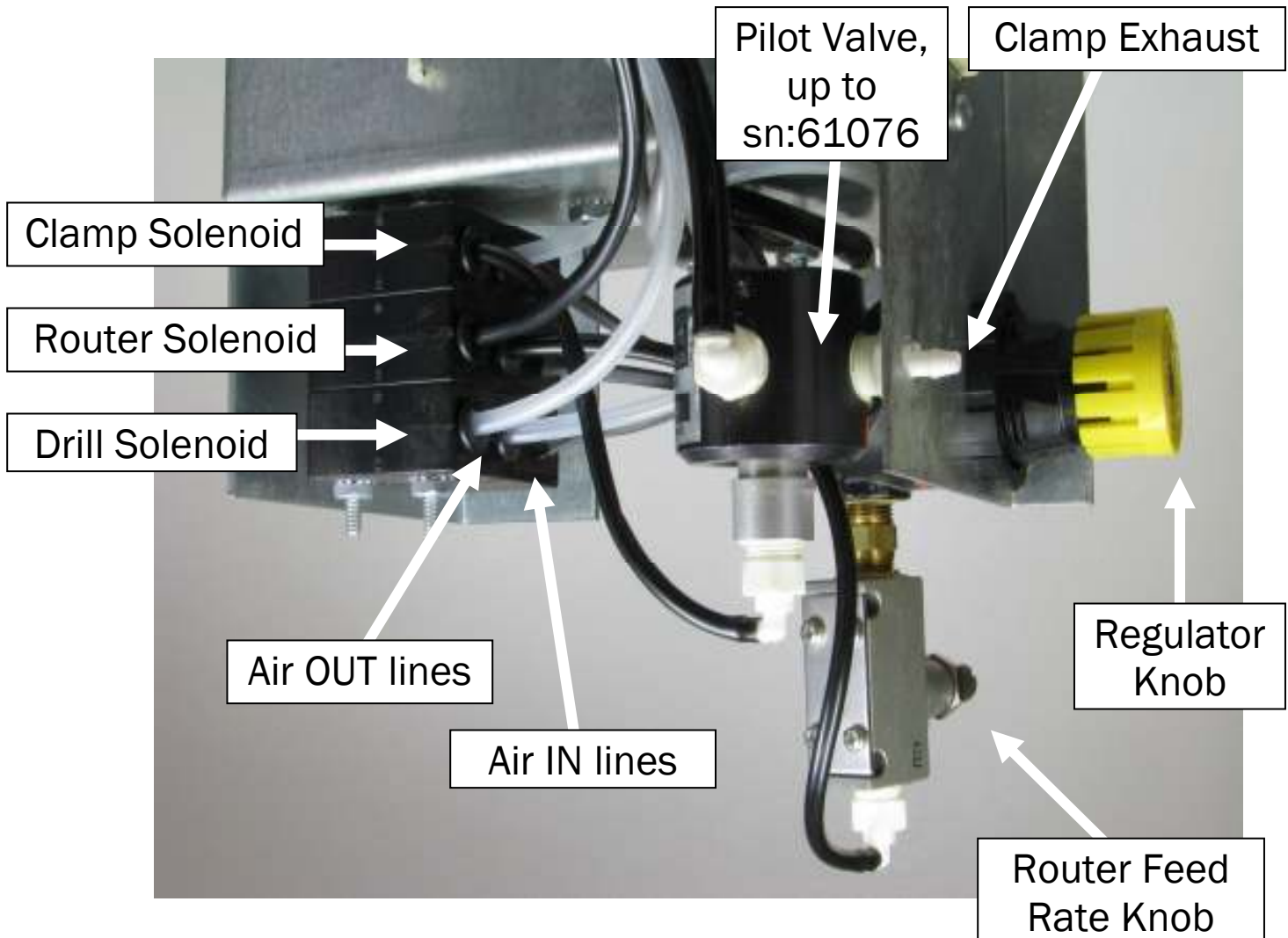



Castle TSM-21

Appendix D Solenoid, Pneumatic Diagram 21.94

Up to SN: 61036

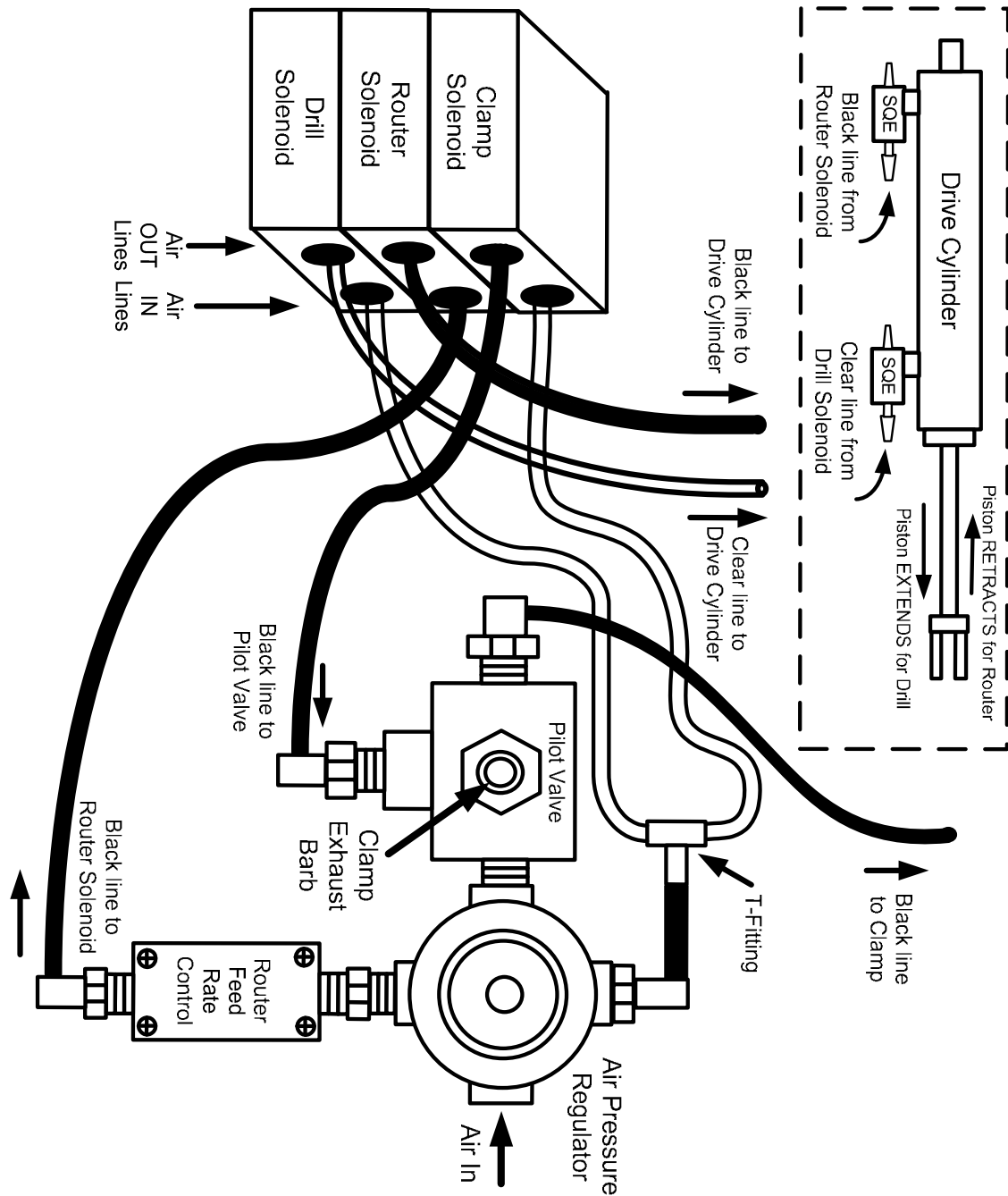



Castle TSM-21

Appendix E

Control Box Works

21.93

SN: 61076 and above

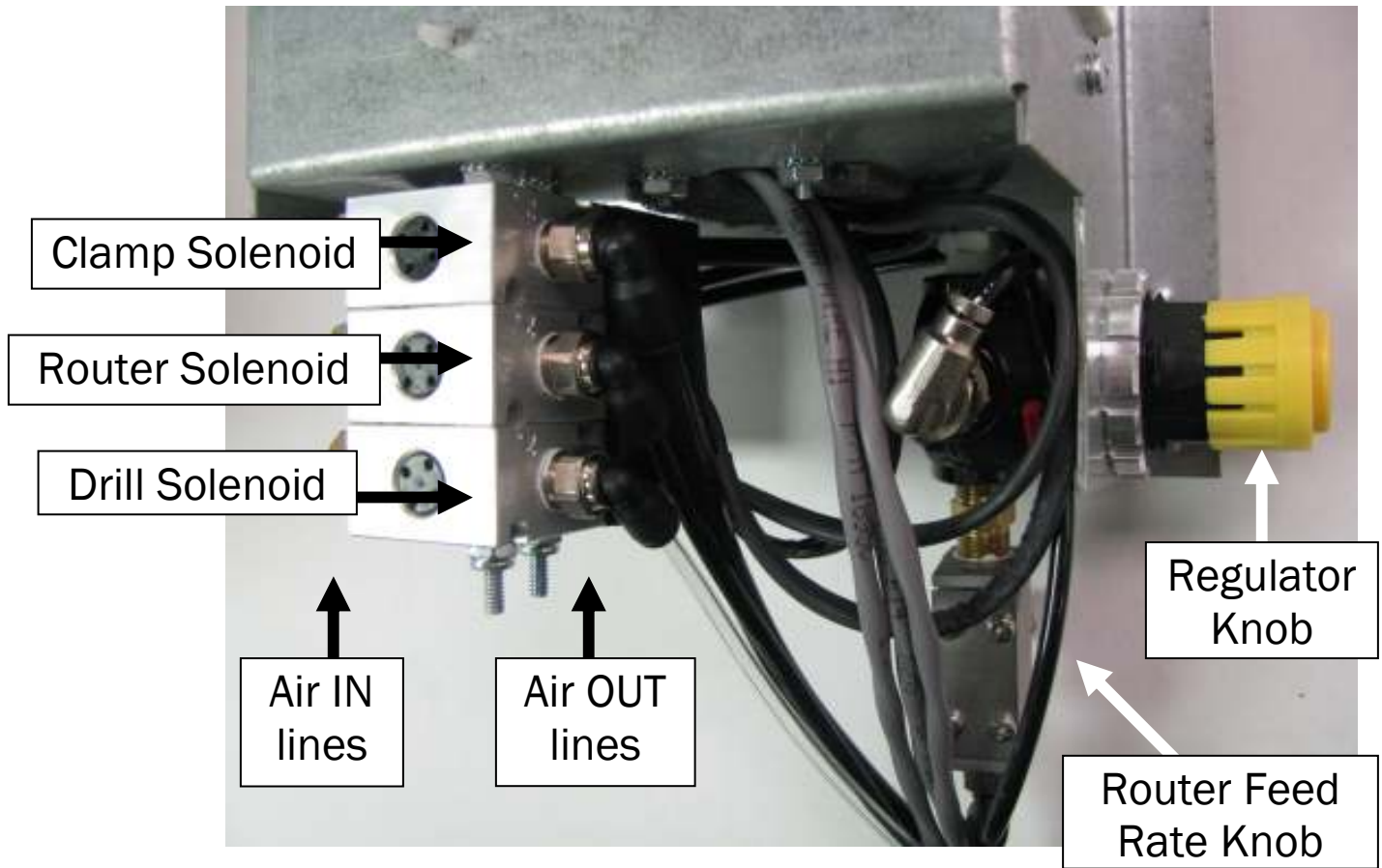

View from front of machine with work top removed

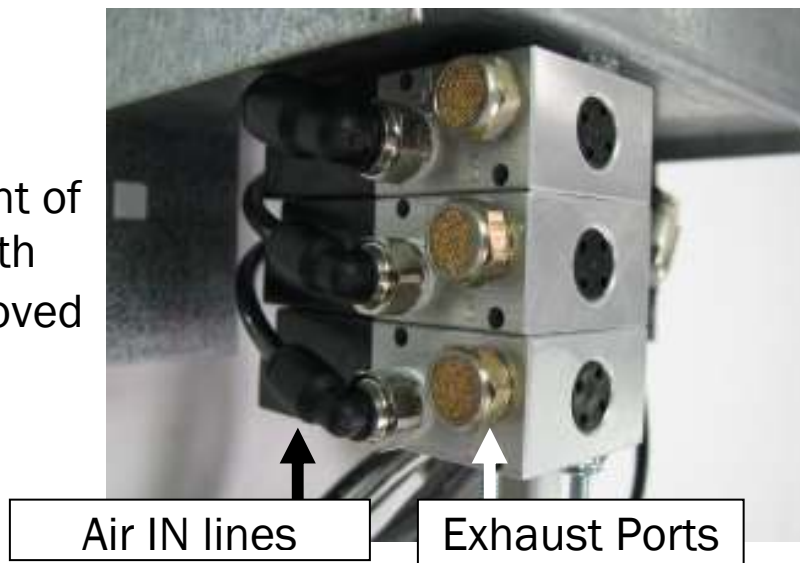



Castle TSM-21

Appendix F Solenoid, Pneumatic Diagram 21.94

SN: 61076 and above

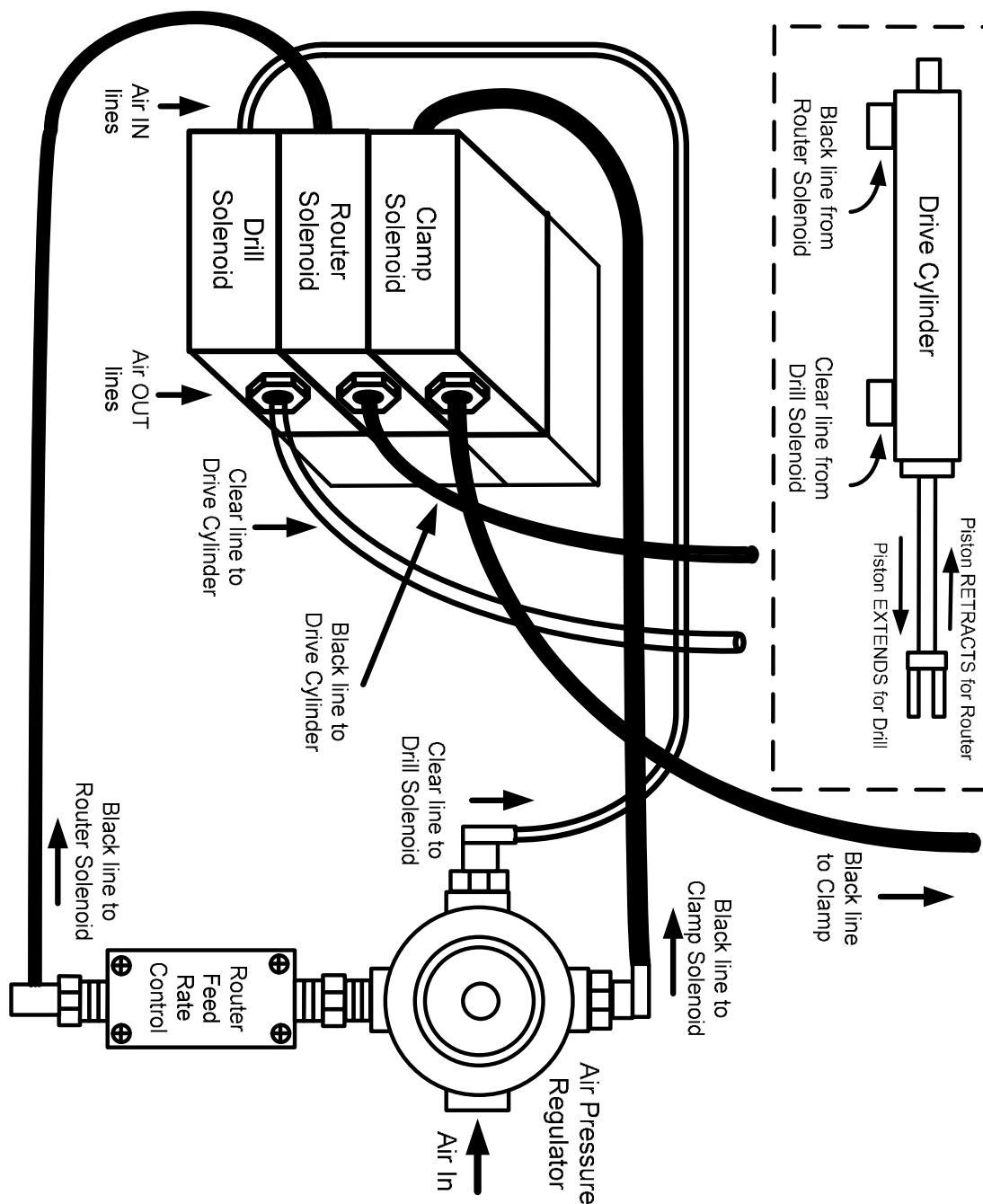



Castle TSM-21

Appendix G

Index

	Page	Section
Air Pressure Regulator, Setting	43	21.90
Air Supply, Attaching	46	21.92
<u>Clamp</u> Cylinder, Air Line Check	14-15	21.12
<u>Clamp</u> Foot Pad, or Cylinder Replacement	10	21.01
<u>Clamp</u> Solenoid, Function check	12-13	21.11
<u>Clamp</u> Solenoid, Unclogging	11	21.10
<u>Control Box Works, Reference, Appendix C & E (note serial #)</u>	49 & 51	21.93
<u>Drill</u> Motor Operation	27-28	21.40
<u>Drill</u> Settings & Bit Depth	29	21.41
<u>Drill</u> Single Coil Bar Spring	30	21.42
<u>Drill</u> Solenoid, Function check	34-35	21.51
<u>Drill</u> Solenoid, Unclogging	33	21.50
<u>Drill</u> Stop Switch, normally closed (NC)	31-32	21.43
Drive Cylinder, Check	36-37	21.60
Drive Cylinder, SQE (Super Quick Exhaust) valve	38-39	21.61
Dry Cycle Testing	4	21.95
Foot Switch, normally open (NO)	41	21.80
<u>Machine Safety, Appendix A</u>	47	21.96
Pilot Hole, Alignment	40	21.72
Pilot Valve, Exhaust Check	16	21.13
Pilot Valve, Check & Replacement	17	21.14
Resetting the Machine	42	21.81
<u>Router</u> Feed Rate Adjustment	26	21.32
<u>Router</u> Motor Operation and Servicing	18-19	21.20
<u>Router</u> Solenoid, Function check	24-25	21.31
<u>Router</u> Solenoid, Unclogging	23	21.30
<u>Router</u> Stop Switch, normally closed (NC)	21-22	21.22
Safety Buttons / Safety Switch, normally open (NO)	43	21.82
<u>Solenoid, Pneumatic Diagram, Appendix D & F (note serial #)</u>	50 & 52	21.94
Solenoid Valves, Replacing	44-45	21.91
Tooling, Check & Replacement	44-45	21.83
Web adjustment with the Router Stop Plate	20	21.21
<u>Wiring Diagram, Appendix B</u>	48	21.84